

Was ist das
für 1 Design?

Vong Domain her

@hschwentner

www.karlsruher-entwicklertag.de



2017

Karlsruher Entwicklertag

Sponsoren

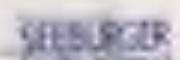
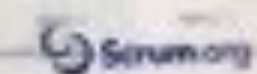
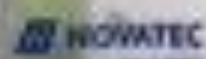
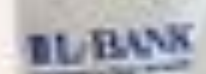
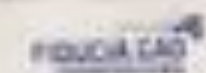
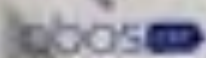



Schlossgärtnerei

Teehaus

Fasanengarten

Schlossgarten

Schloss

Chinesische Teehäuschen

Botanischer Garten

Fasanenschlösschen

BVeriG

Ehrenhof

Staatliche Kunsthalle

Schlossplatz

KIT Campus Süd

Denkmal

Schlossgarten



HENNING

SCHWENTNER

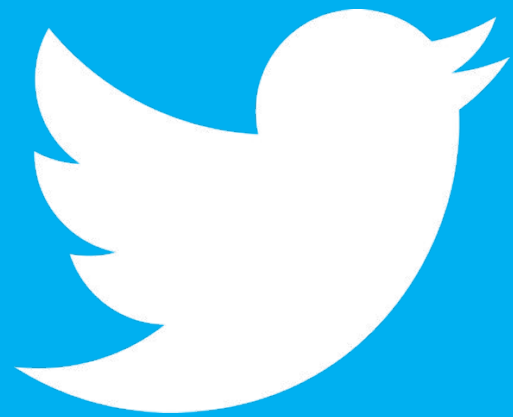

*@*hschwentner









speakerdeck.com/hschwentner

@hschwentner



Quelle: <http://www.schulbilder.org/malvorlage-informatiker-i10418.html>





Foto: Henning Schwentner

**Fritz &
Franz &
Lothar &
Philipp.**







Neugersdorfer Hütte
 am Himmelst. Jauern
 der Sektion Warnsdorf D. u. O. A.-U.

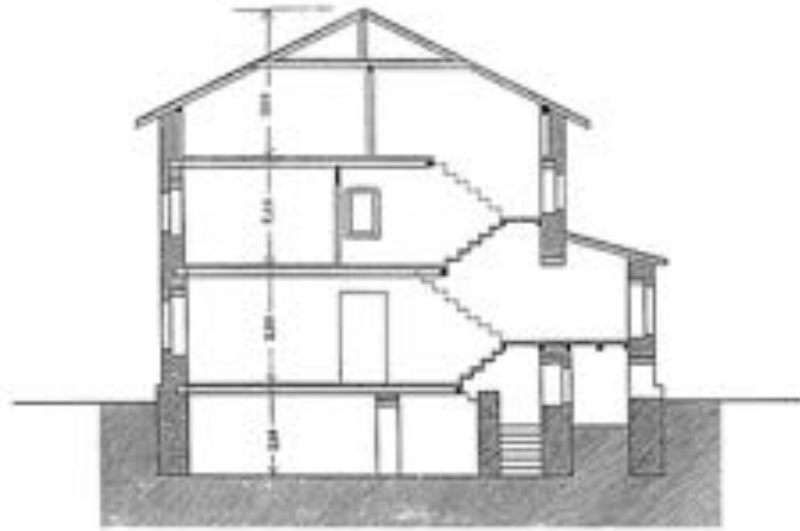

Querschnitt



Ansicht



Erstes Geschoss

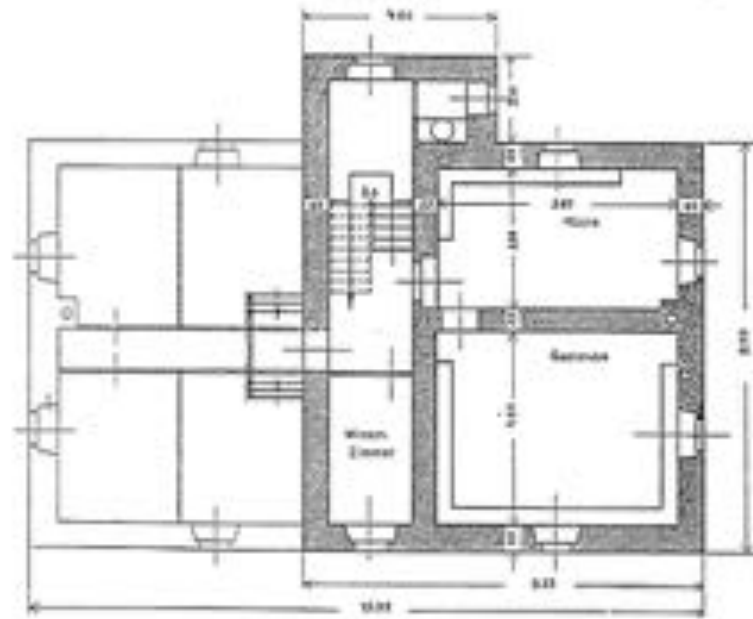

Erdgeschoss



Foto: Steindy/Wikipedia





C#







WORKPLACE
SOLUTIONS



Die Legende von Paul und Paula



Mit den PUHDYS-Hits
"Wenn ein Mensch lebt"
"Geh zu ihr"





Wilhelm Paula Siegfried





Vong WPS her

Mit den PUHDYS-Hits
"Wenn ein Mensch lebt"
"Geh zu ihr"

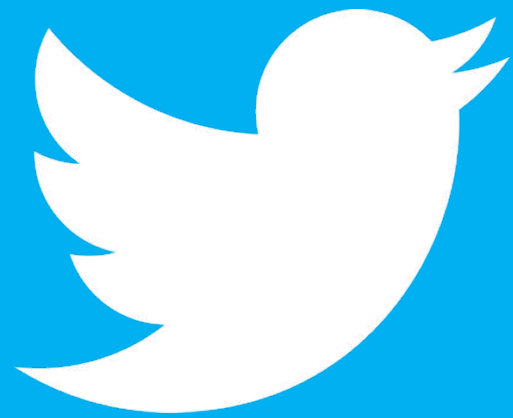

@wps_de

@hswentner



»Business-Software
die Spaß macht«



Foto: B. Bertram/Wikipedia

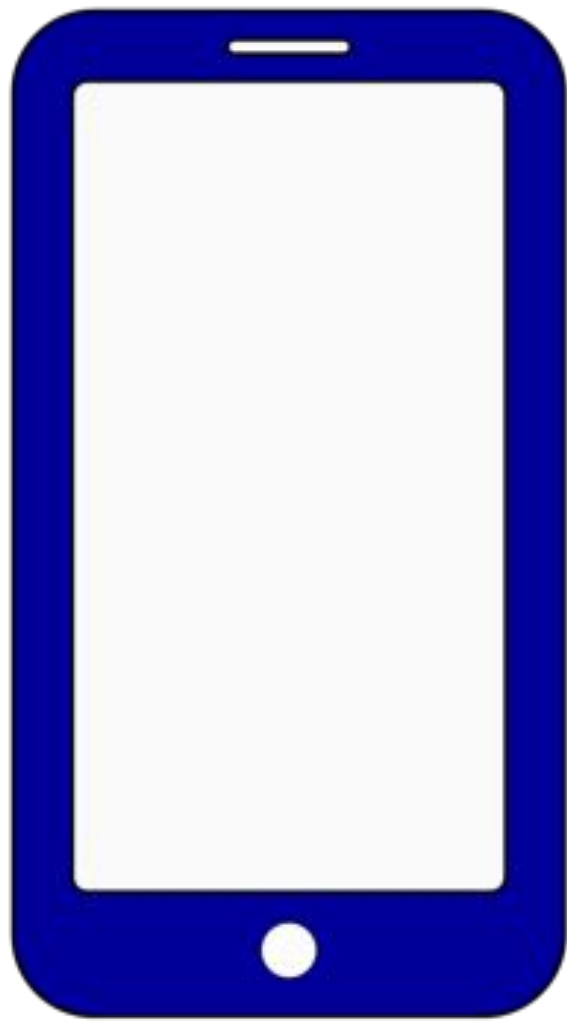



Foto: Pixeden/Wikipedia





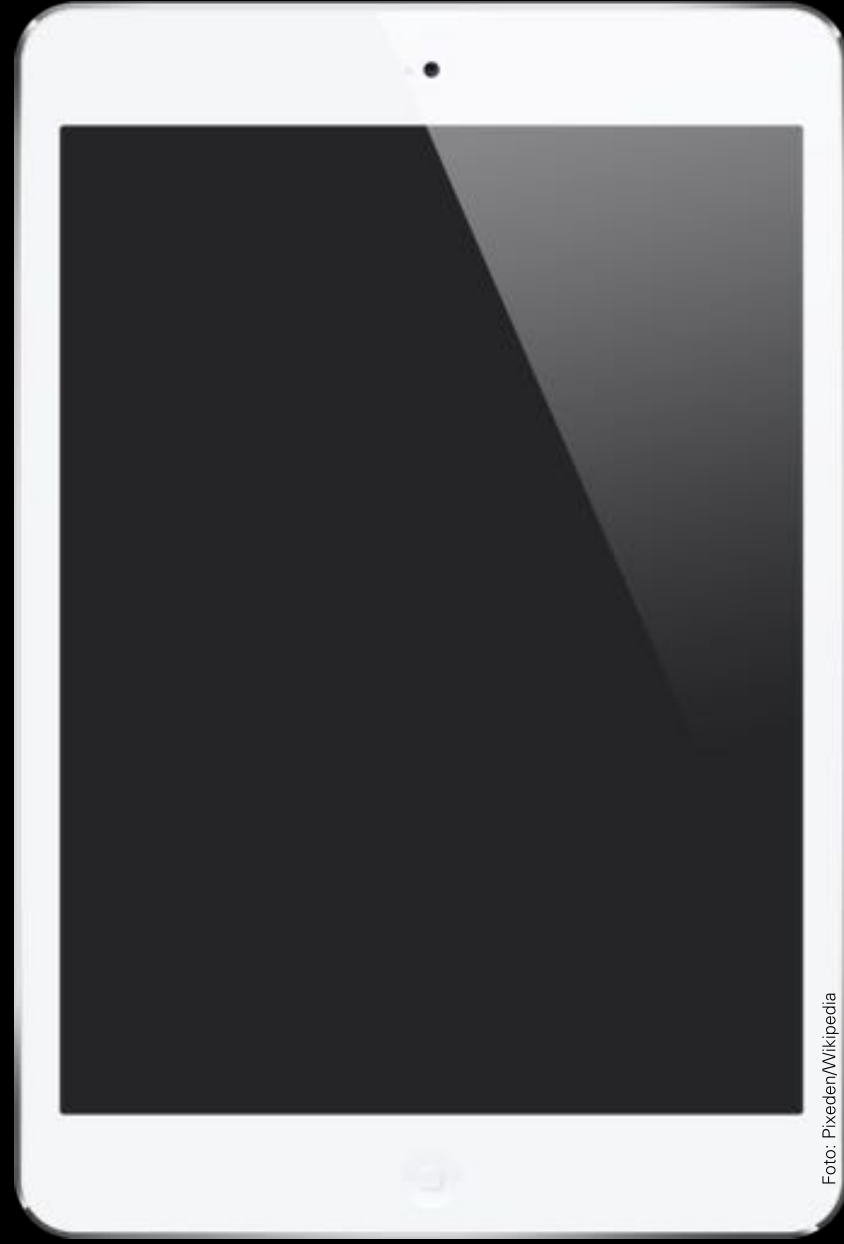

»Business-Software
die Spaß macht«

Domain-Driven

DESIGN

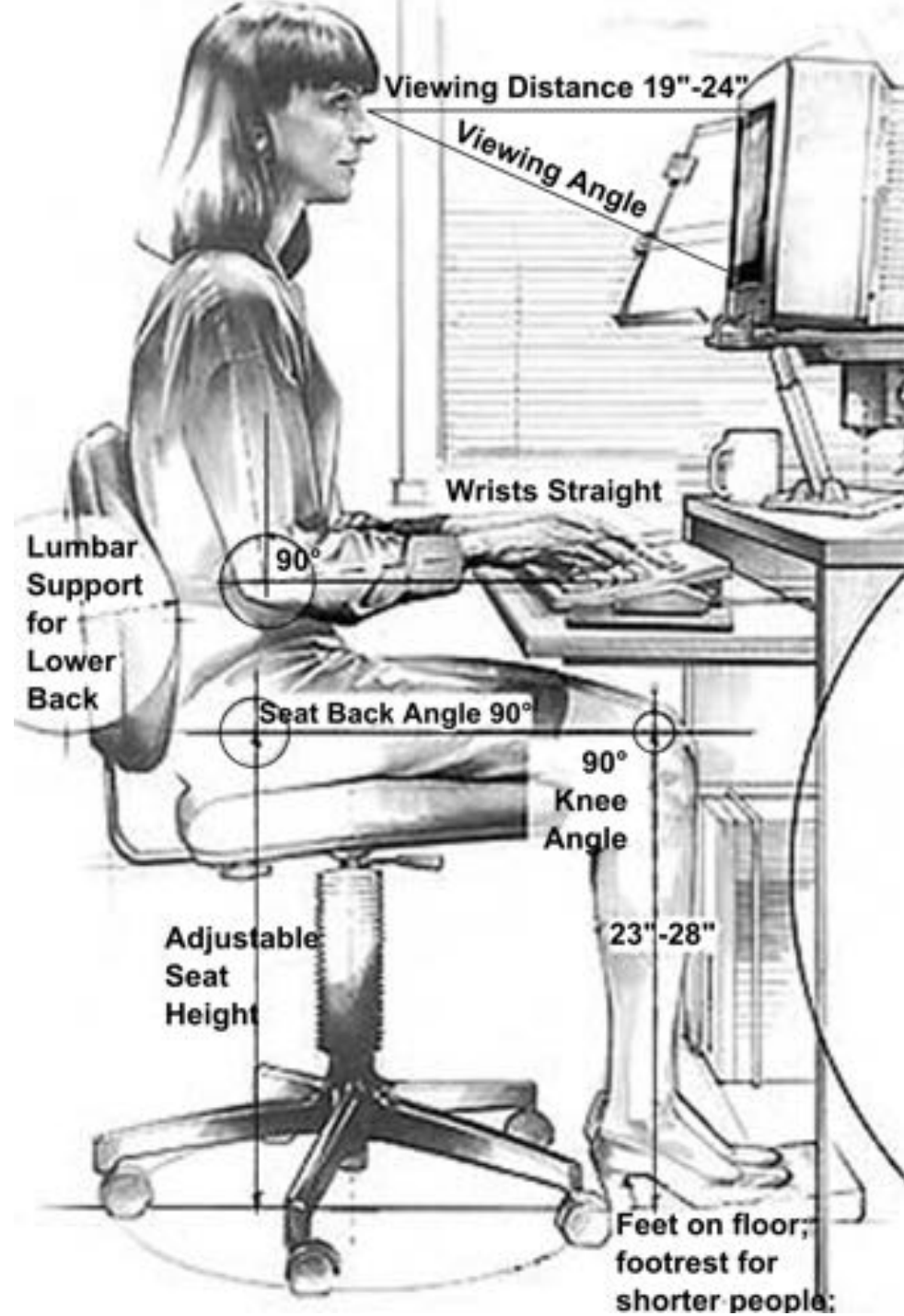

Inhalt



Tactical Design

Entity

Bausteine

Aggregate

Factory

Value Object

Ubiquitous Language

Domain Expert

Event Storming

Bounded Context

Context Mapping

Domain Model

Strategic Design

Hexagonal Architecture

Microservices

CQRS

Event Sourcing

Scrum

Agile

Extreme Programming

Design by Contract







Foto: Rabel/Wikipedia

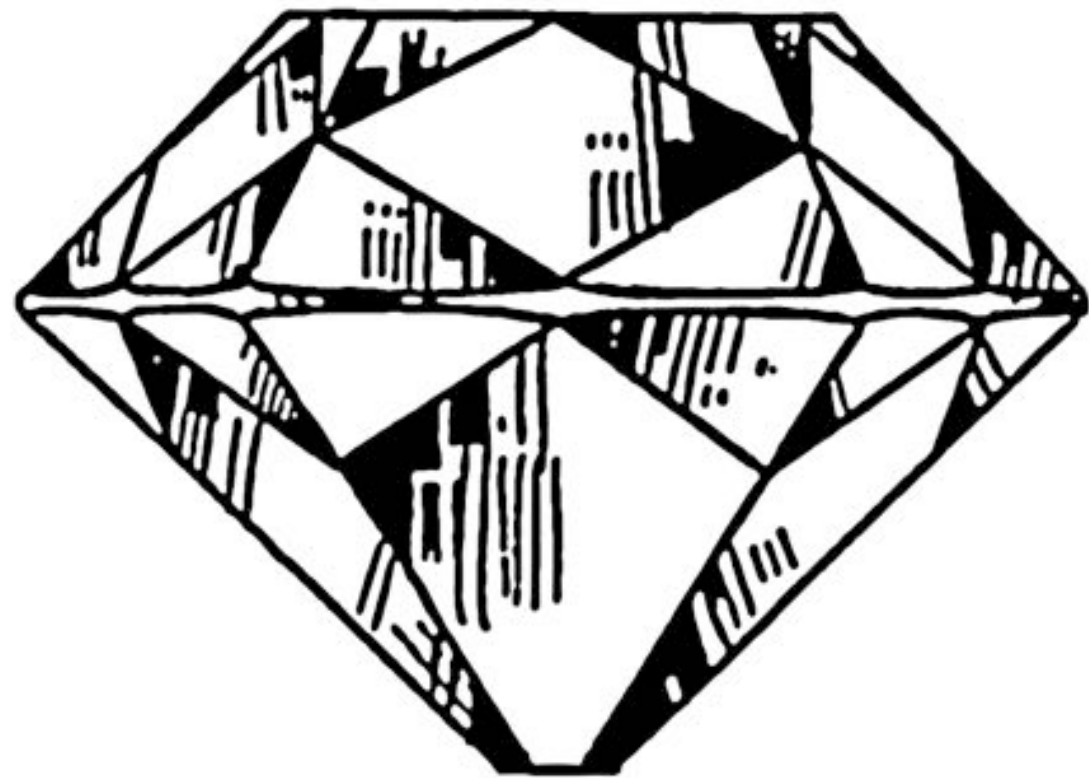

Foto: Xocolatl/Wikipedia



The Programmers Life

WORK



HOME



PLAY



SLEEP



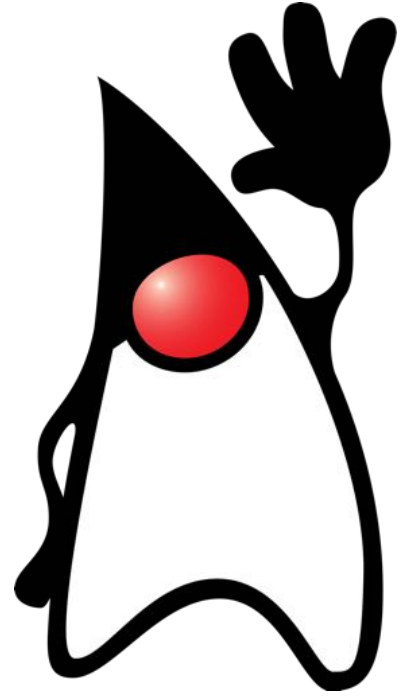

spring

 HIBERNATE



 eclipse

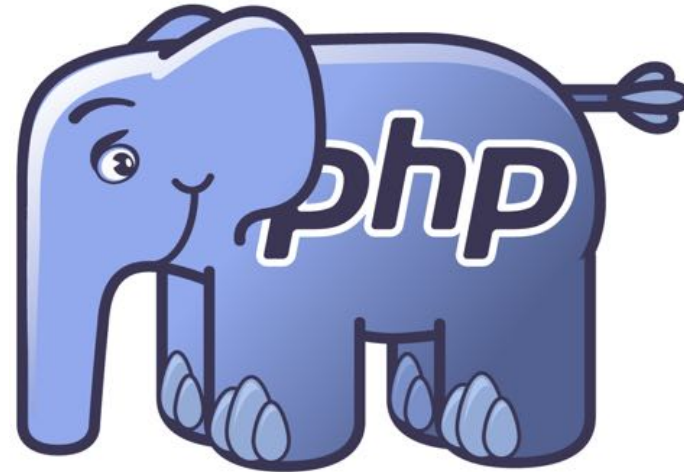





Software != Selbstzweck



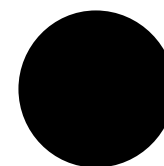
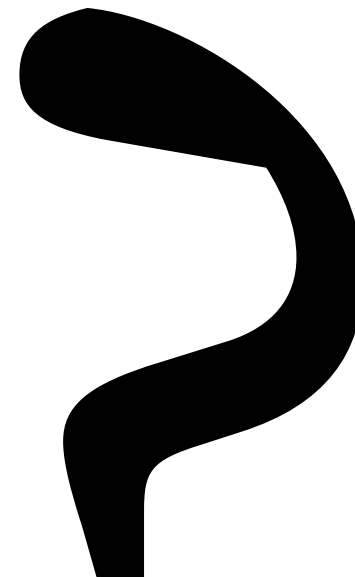
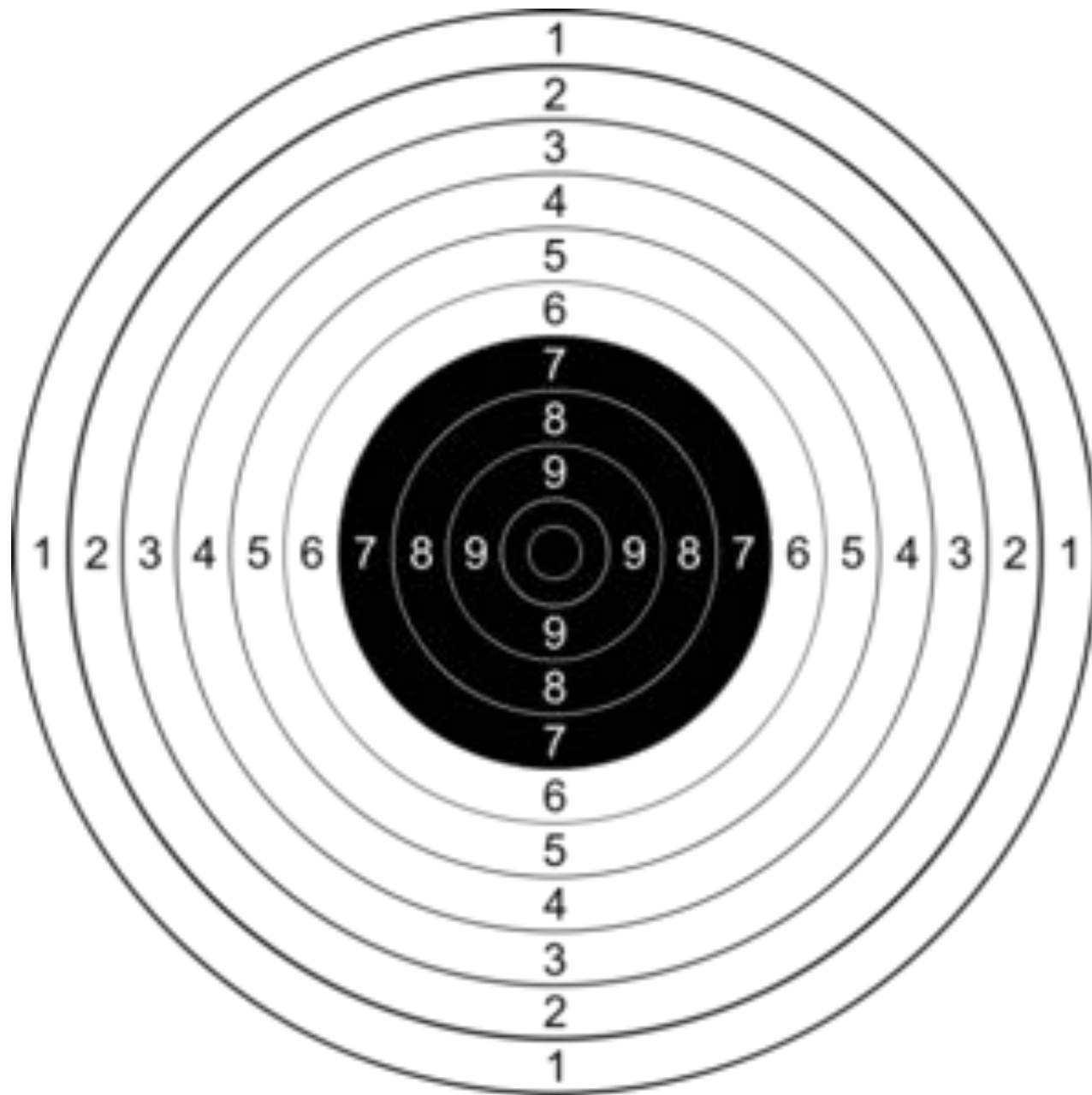



WICHTIG!

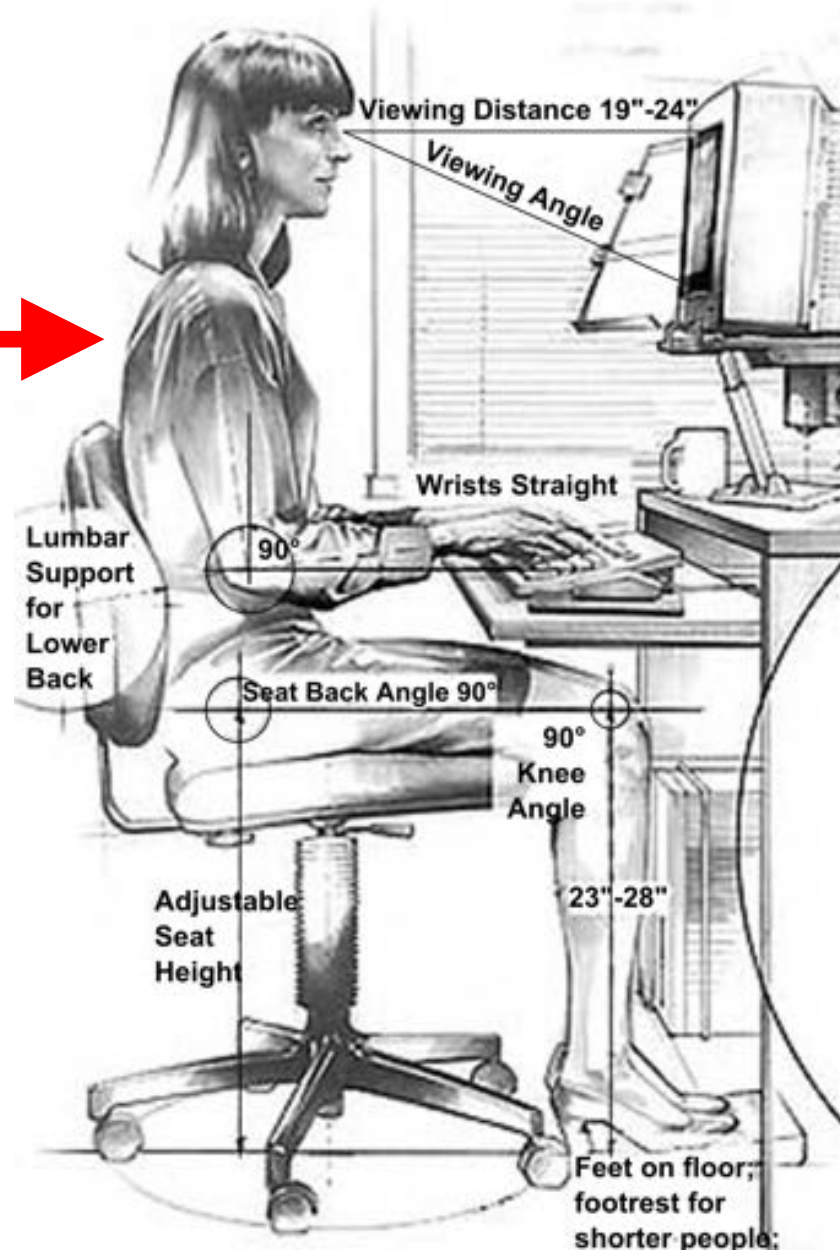

Domain-Driven

DESIGN



Software



Domäne





Fach-
wissen







BIG



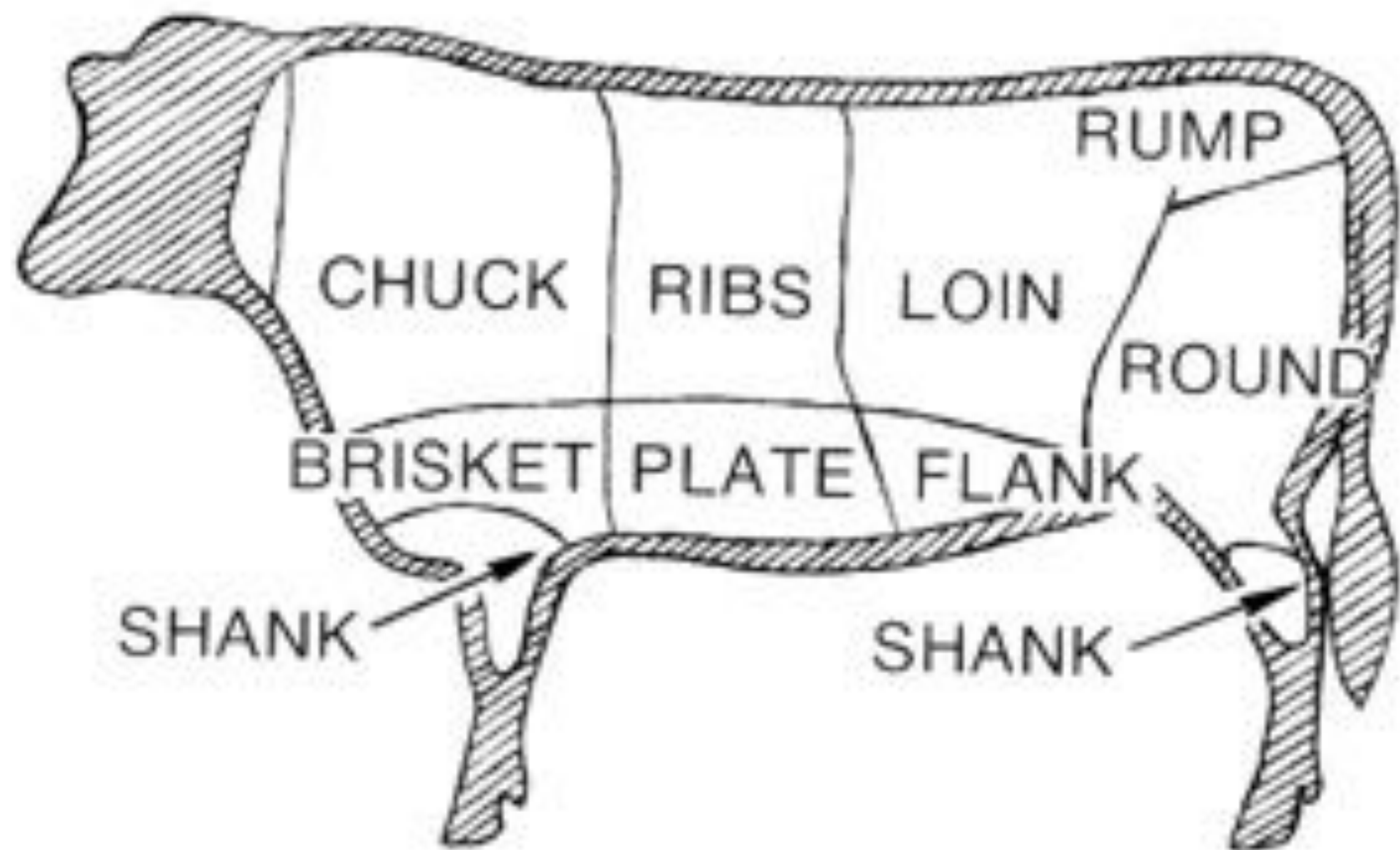





Bounded Context







SMALL

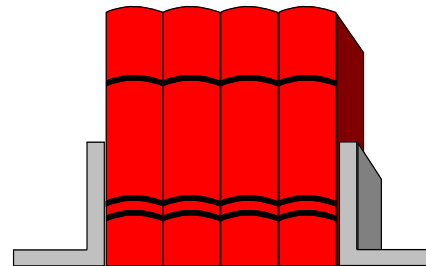
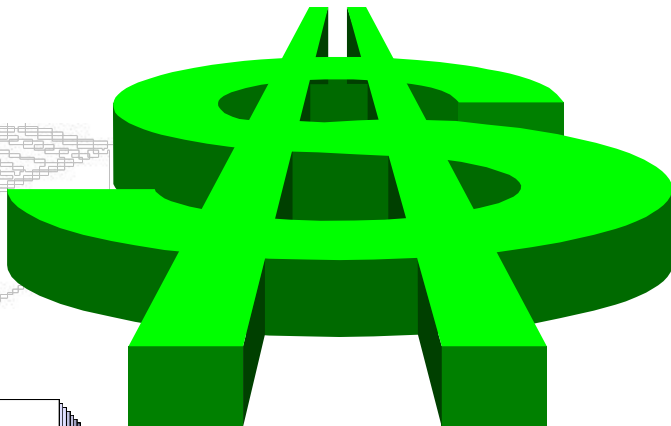
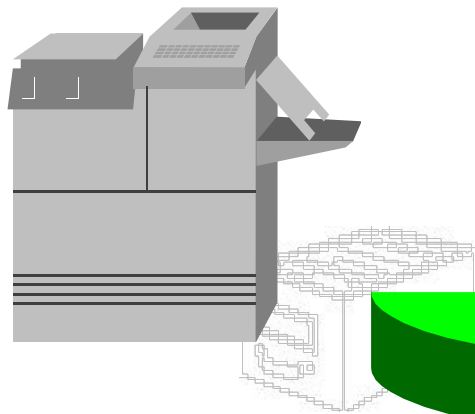

BOB JONES	DATE _____	2048
PAY TO THE ORDER OF _____	\$ _____	DOLLARS
FIRST NATIONAL BANK		
⑆00 2100 66⑆ 770⑆ 964076⑆ 2121		

1992						
			1	2	3	4
5	6	7	8	9	10	11
12	13	14	15	16	17	18
19	20	21	22	23	24	25
26	27	28	29	30	31	

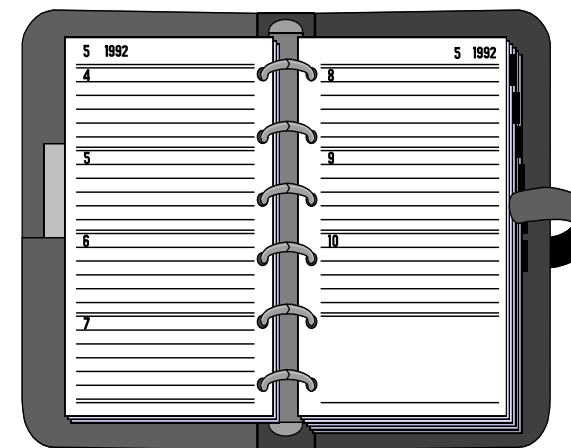
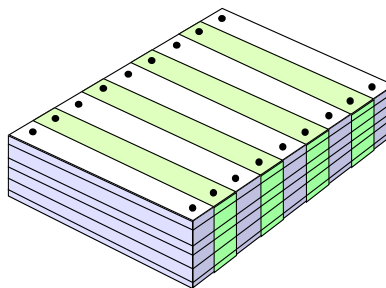
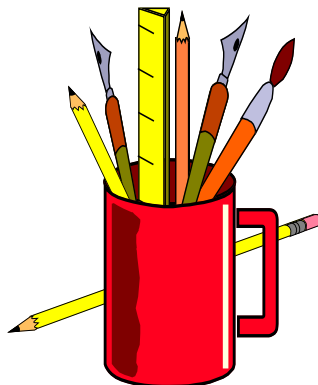
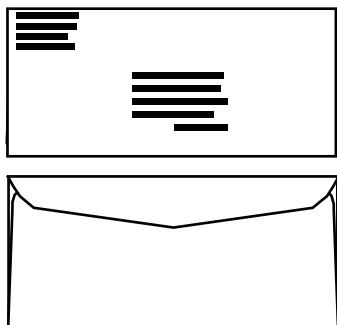
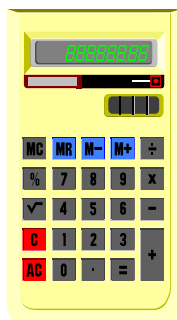
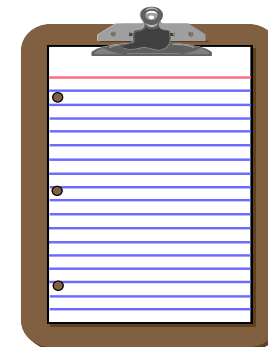
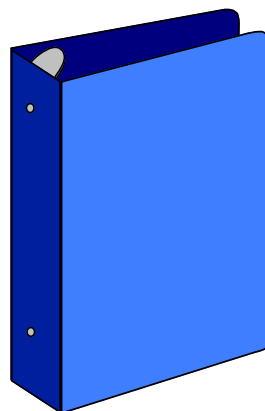

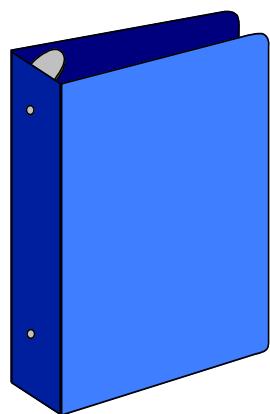

```
public class Konto
{
    //...
}
```

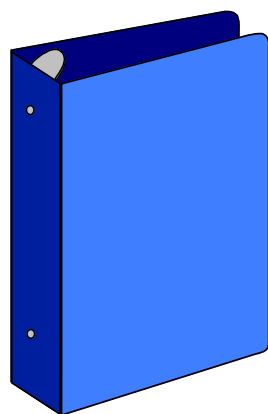

```
public class Konto
{
    public void zahleEin(Betrag b)
        //...
}
```



```
public class Konto
{
    public void zahleEin(Betrag b)
    //...
    public void zahleAus(Betrag b)
    //...
}
```



```
public class Konto
{
    public void setSaldo(Betrag b)
    //...
}
```



```
public class Konto
{
    public void setSaldo(Betrag b)
    //...
}
```



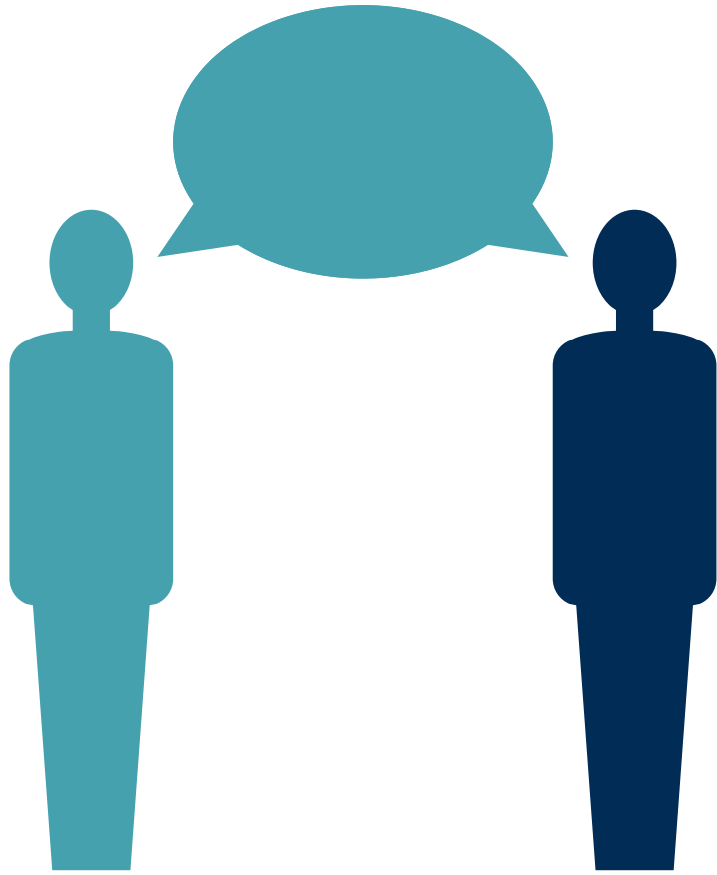

ELECTROLA

KLING
KLANG

MC 006-78.078

KRAFTWERK DAS MODELL

DEUTSCHE VERSION



NOCH ALS MAXI-SINGLE
ERHÄLTLICH

Flacc

Karl

Wolfgang

Florian

The Programmers Life

WORK



HOME



PLAY



SLEEP



Technische Sprache

@hschwentner

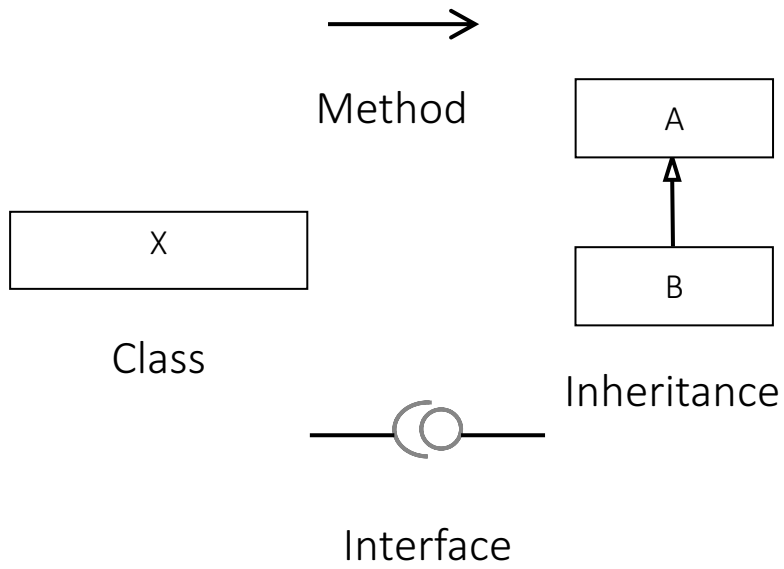

Eclipse



Visual Studio

O/R-Mapping



Client



Database



Server

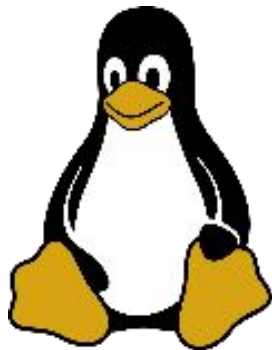

Linux



Windows



Fachsprache

@hschwentner



Frachtbrief

4300

Containernummer



Kran



Container



Twistlock







Fachbegriff



Fachbegriff

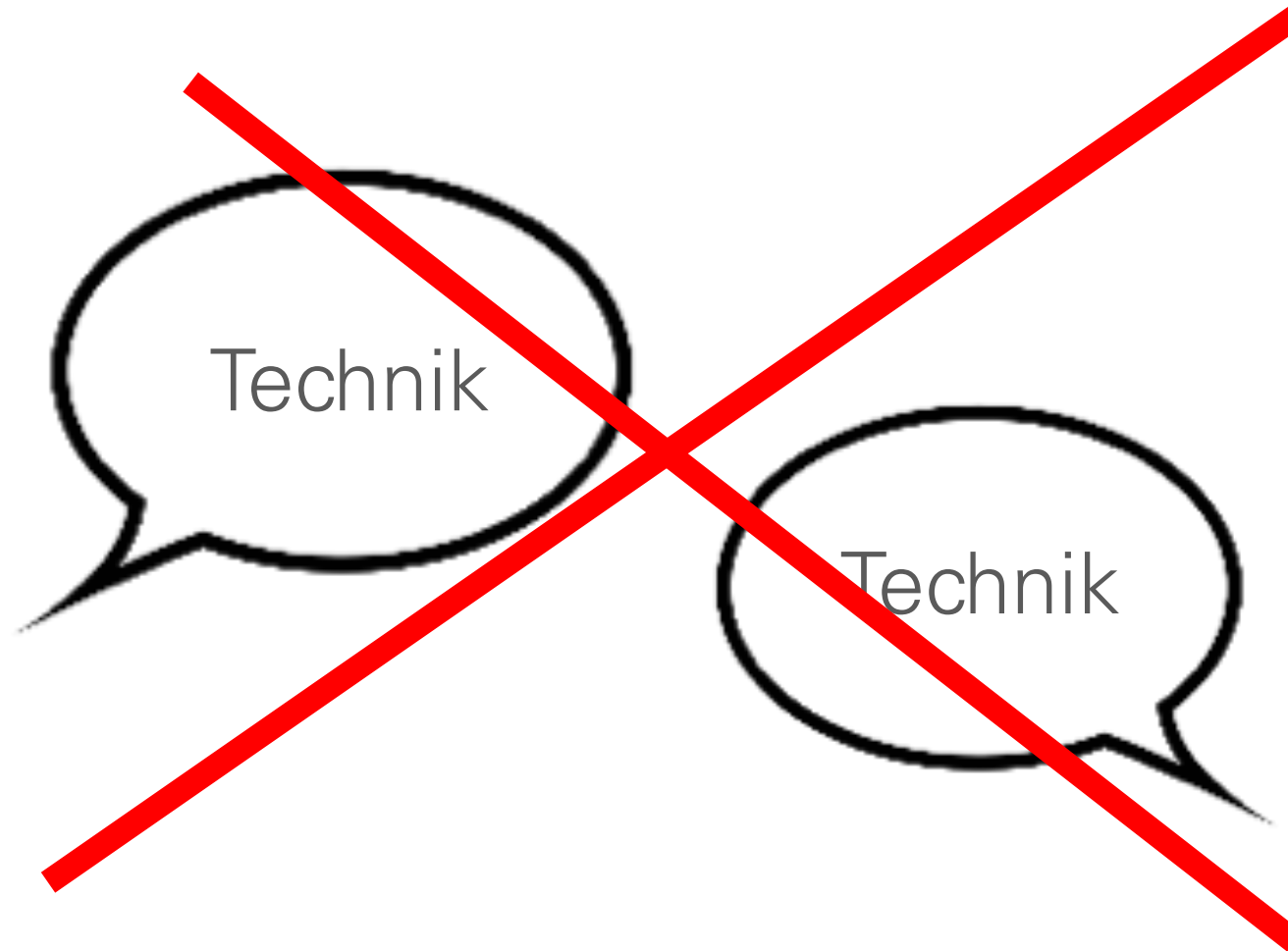

Technik

Technik

Ubiquitous Language

Allgegenwärtige Sprache



Containernummer

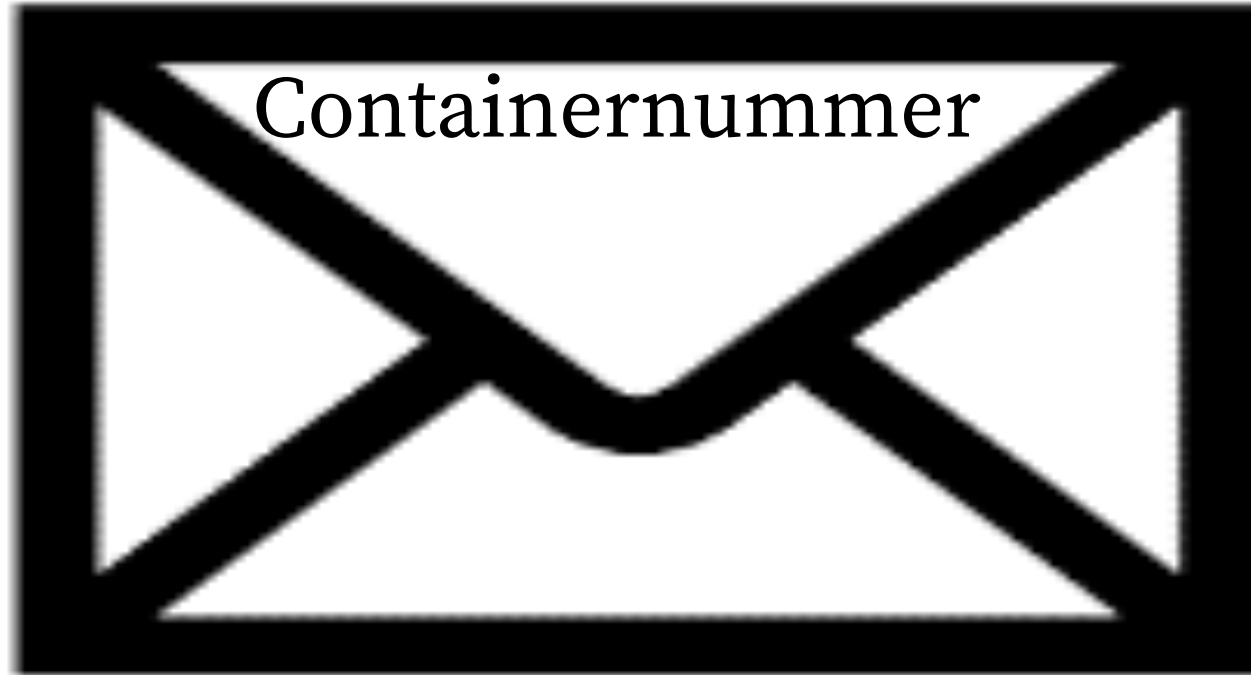

Containernummer

Containernummer



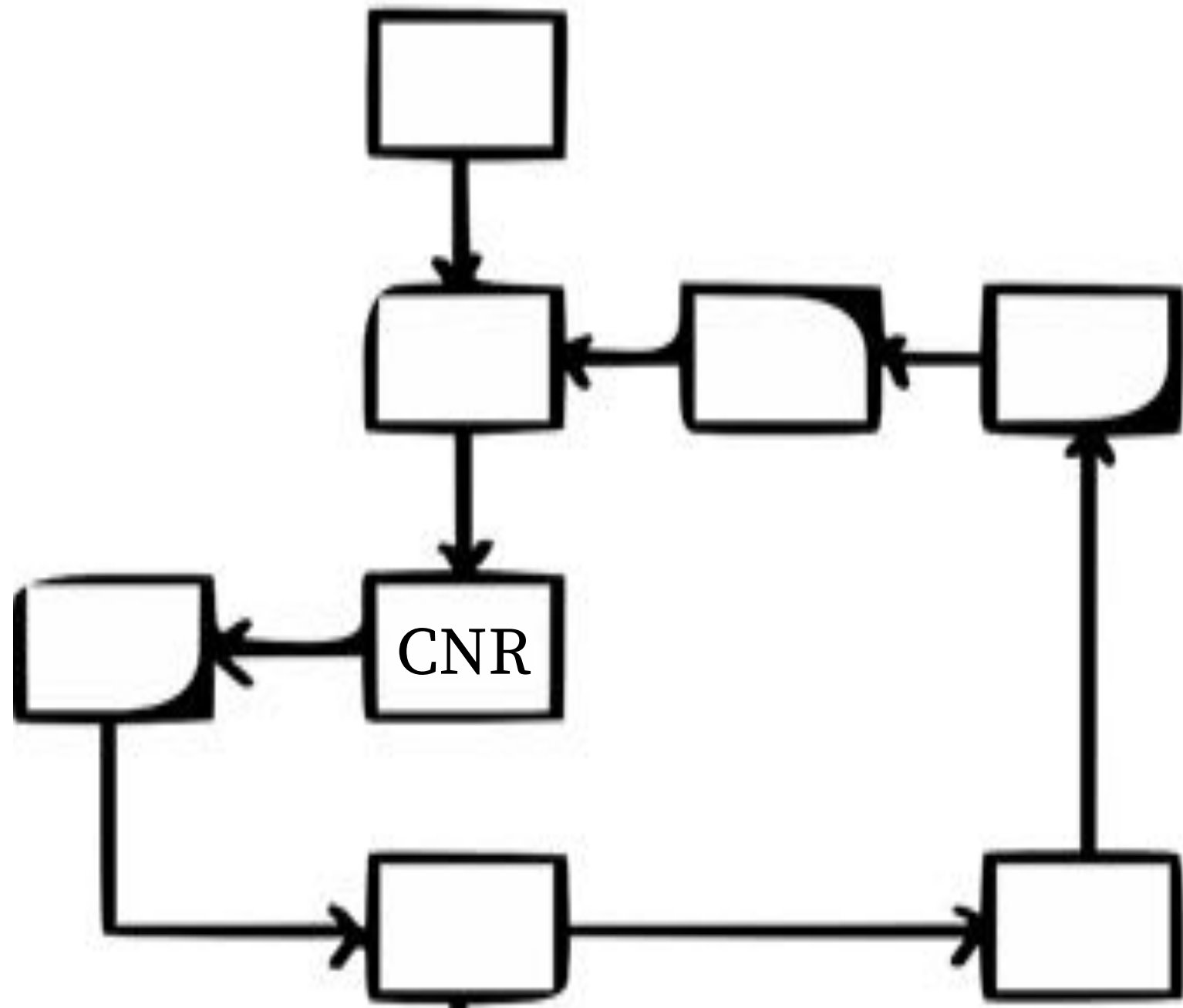

```
public class Containernummer  
{  
    //...  
}
```

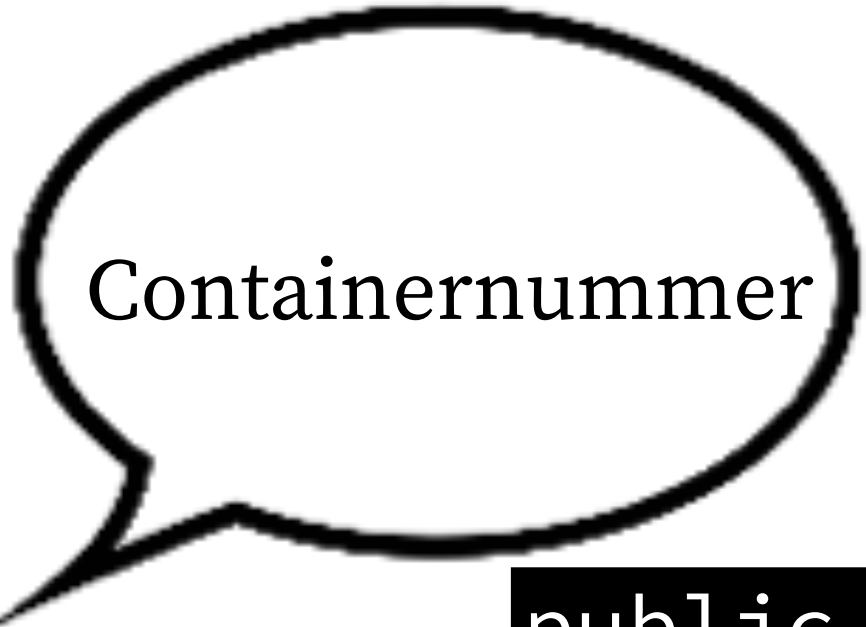

```
public class Containernummer
{
    //...
}
```

*“There are only two hard things in Computer Science:
cache invalidation and naming things.”*

Phil Karlton



*“There are only two hard things in Computer Science:
cache invalidation, naming things,
and off-by-one errors.”*

Phil Karlton







Figuren



Schachuhr



Spieler

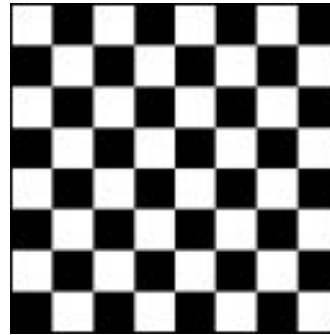

Brett



König



Figuren



Spieler

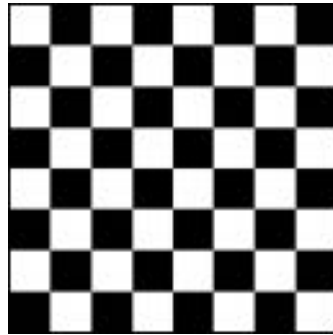

Brett



Figuren



Spieler

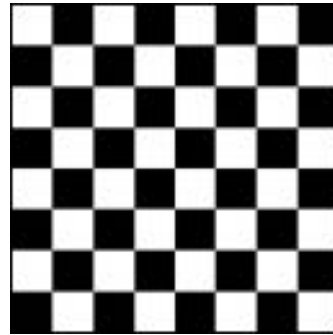

Brett



Nichtmenschlicher
Spieler

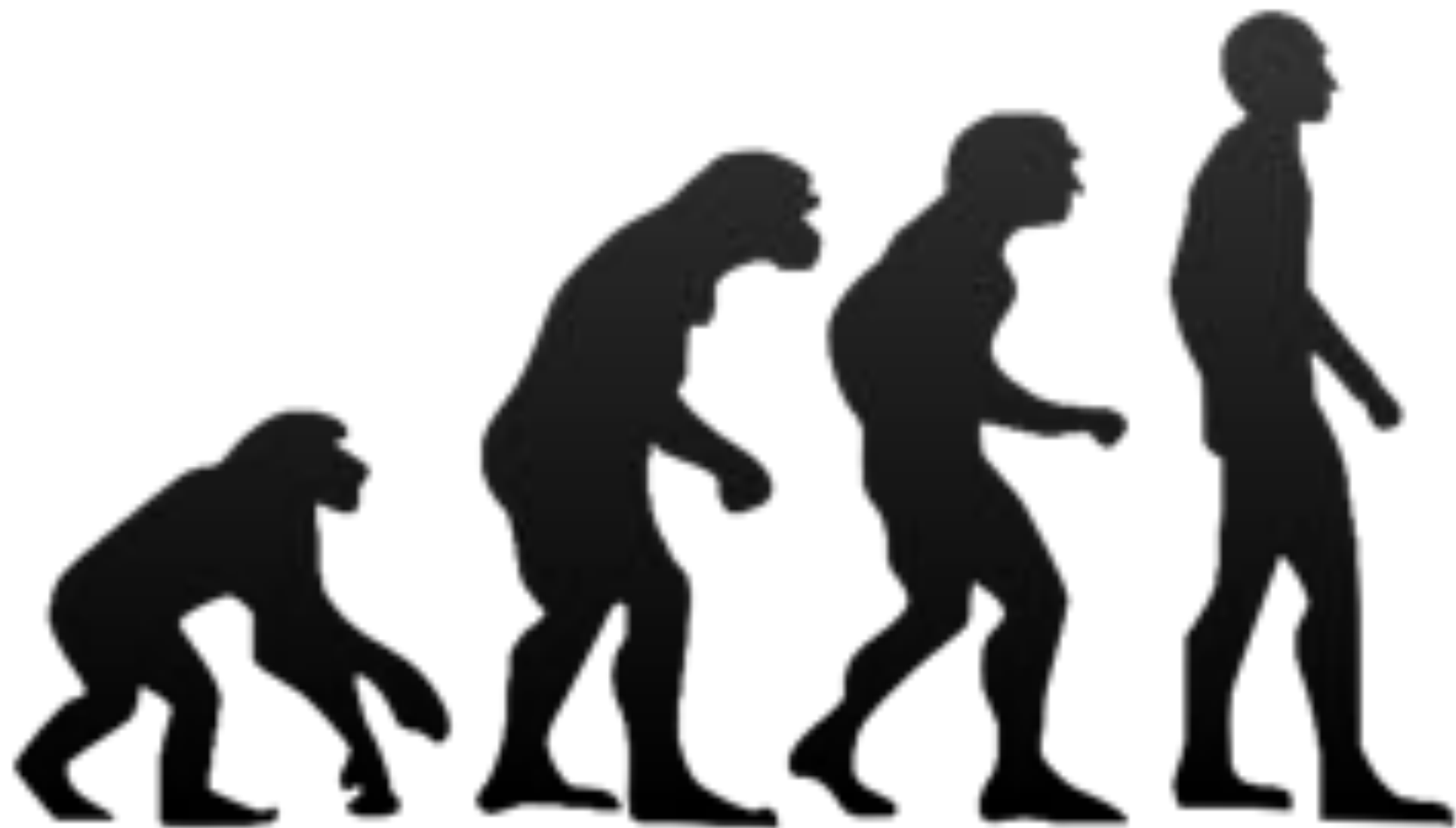







EVENT STORMING

3X
grats

Post-it

3



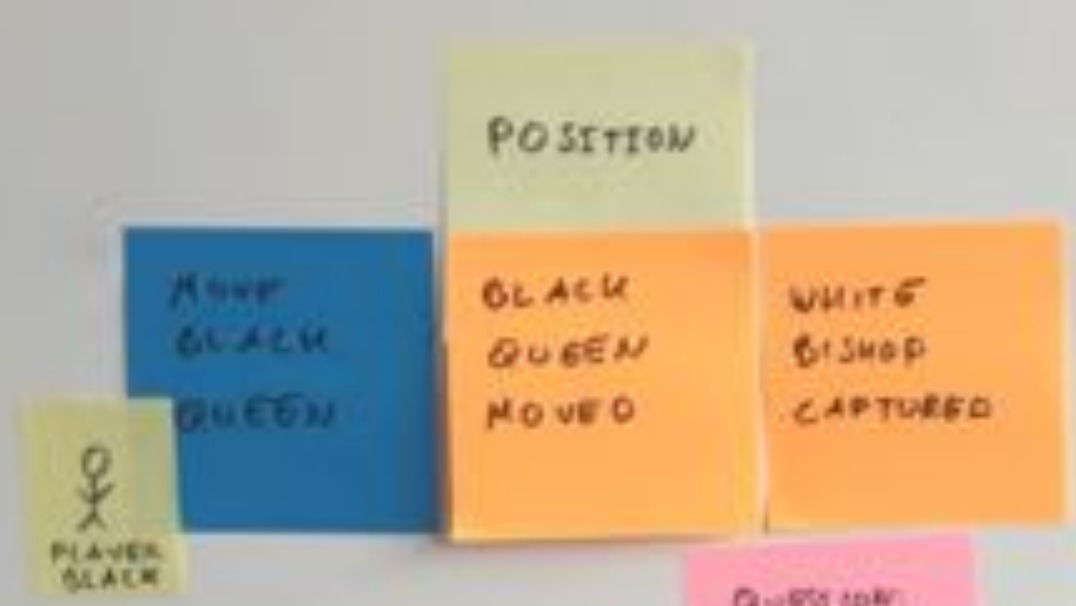

QUESTION:
REALLY TWO
EVENTS CAUSED
BY ONE COMMAND
?

POSITION
THE LOCATIONS
ALL PIECES ON
BOARD





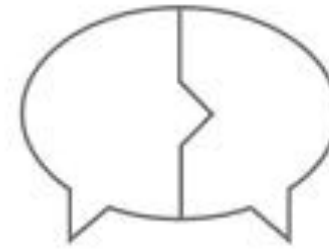

Domain Storytelling

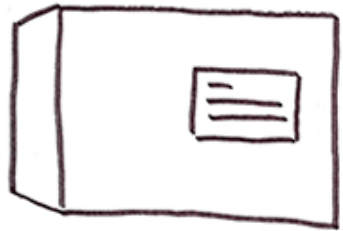

Kassenbelege
①

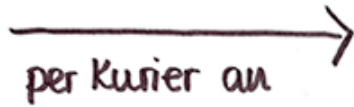

Buchhaltung



Kassenbelege
②

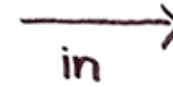

Buchhaltungssystem

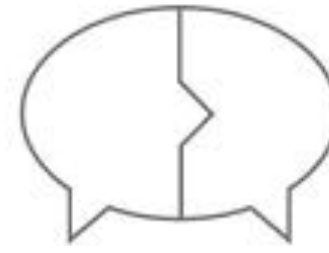

Domain Storytelling

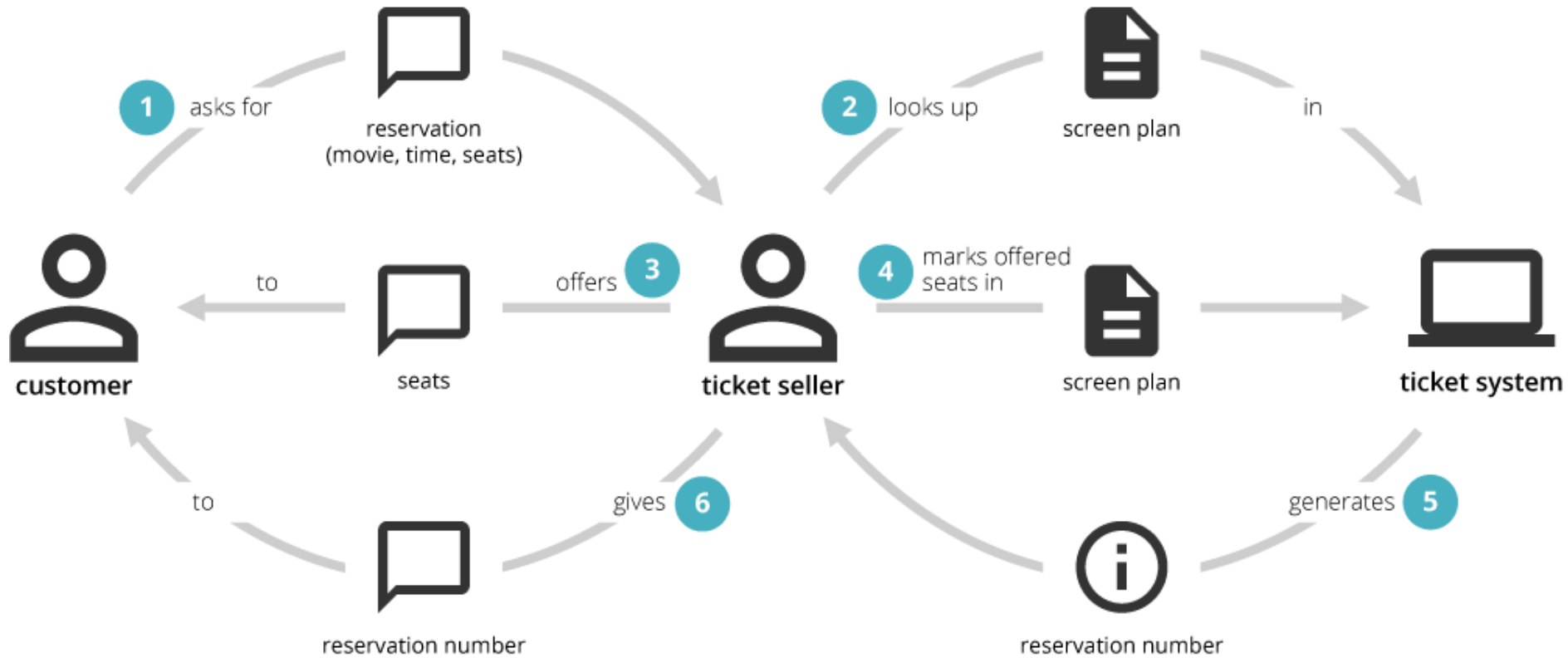

<http://www.domainstorytelling.org>



**A GLOSSARY
OF
PHILATELIC TERMS**

Compiled by the following Committee:

**E. D. BACON, W. DORNING BECKTON
F. A. BELLAMY, P. C. BISHOP, E. B. EVANS,
L. W. FULCHER, F. J. MELVILLE, and
C. J. PHILLIPS**

*Appointed by the Second and Third Philatelic Congresses
of Great Britain, 1892-11*



LONDON:
STANLEY GIBBONS, Ltd., 391 STRAND, W.C.

1912



Tactical Design

@hschwentner



Entity

Auch: Business Object

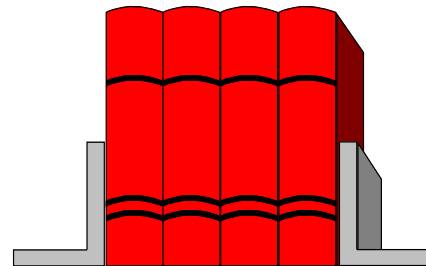
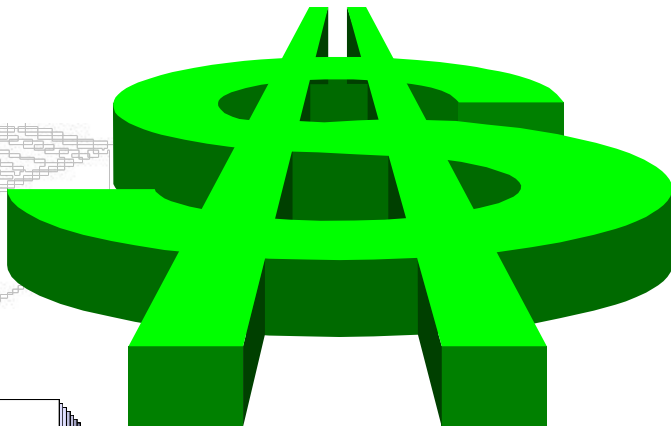
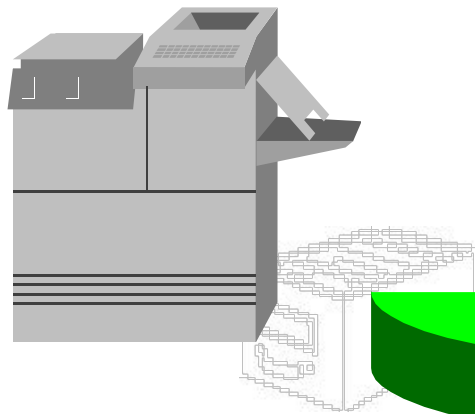

BOB JONES 2048

DATE _____

PAY TO THE ORDER OF _____ \$ _____
DOLLARS

FIRST NATIONAL BANK

⑆00 2100 66⑆ 770 9640761⑆ 2121

1992						
			1	2	3	4
5	6	7	8	9	10	11
12	13	14	15	16	17	18
19	20	21	22	23	24	25
26	27	28	29	30	31	

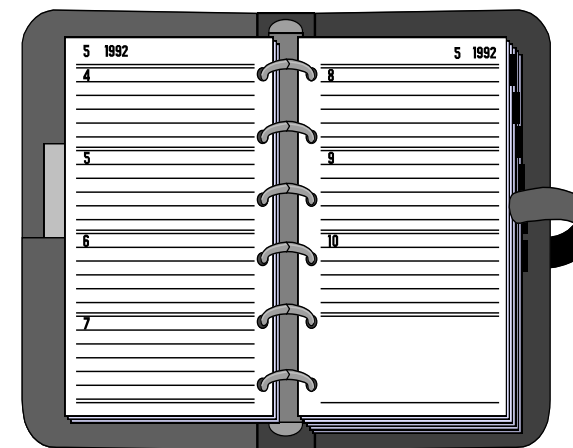
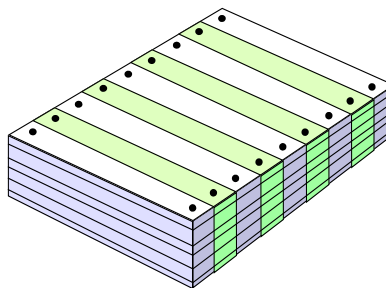
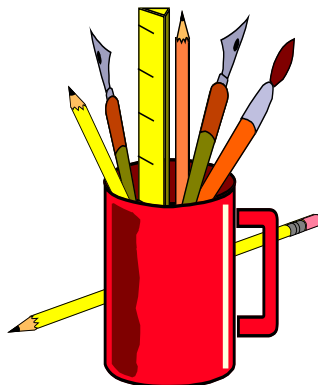
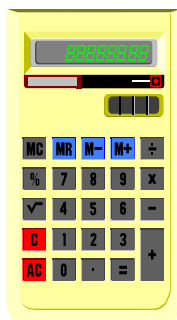
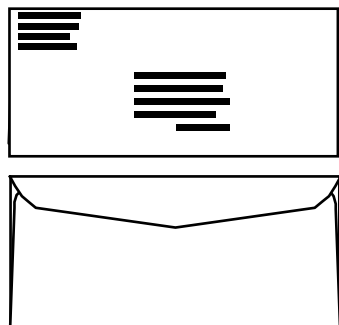
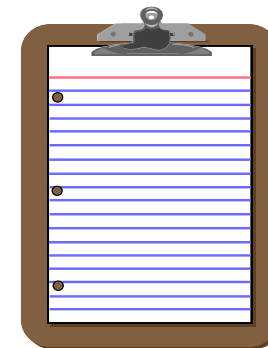
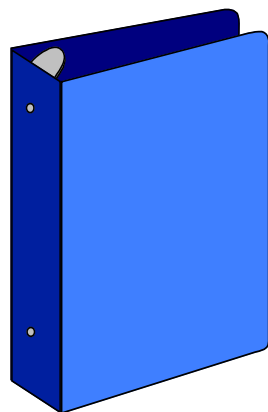



Identität

@hschwentner







Foto: Thomas G. Graf/Wikipedia



Foto: H. Schwentner





Foto: Bernd Schwabe in Hannover/Wikipedia

Versicherungspolice

Baumaßnahme

Urlaubsantrag

Kaufvertrag

Fahrauftrag

Value Object



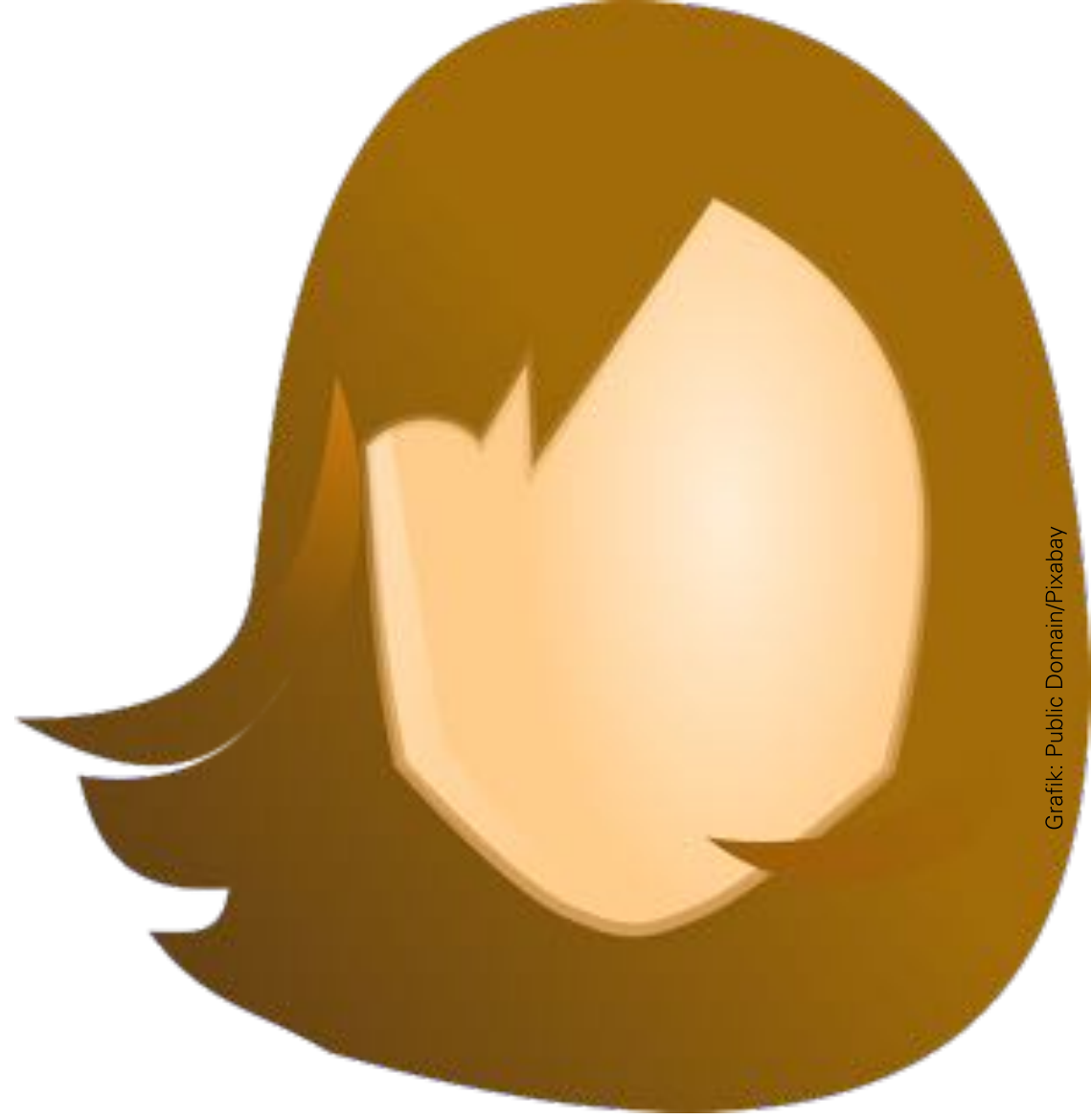

Grafik: Public Domain/Pixabay





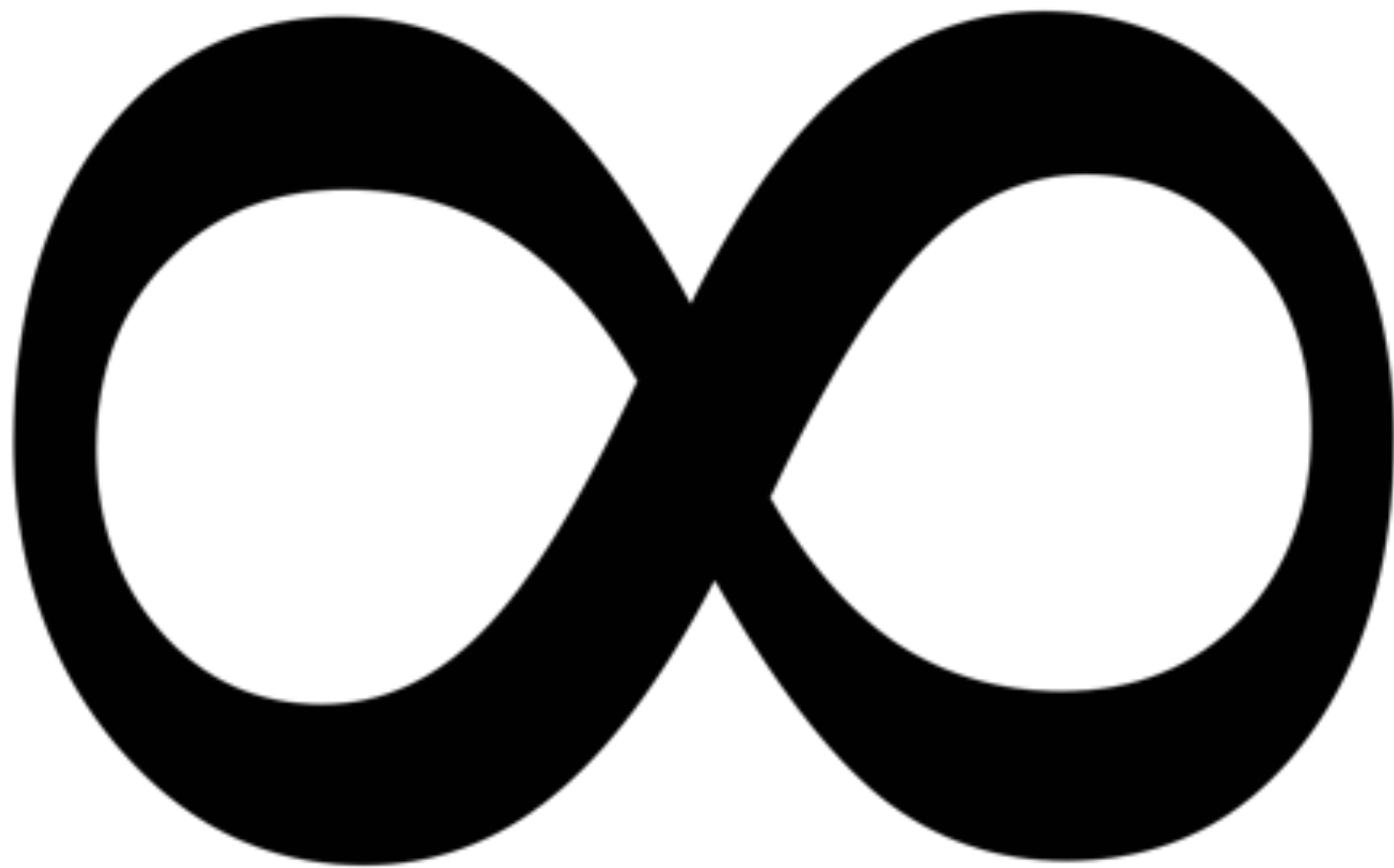

Postleitzahl

IBAN

IATA-Code

GPS-Koordinate

Containernummer

Domain
Event

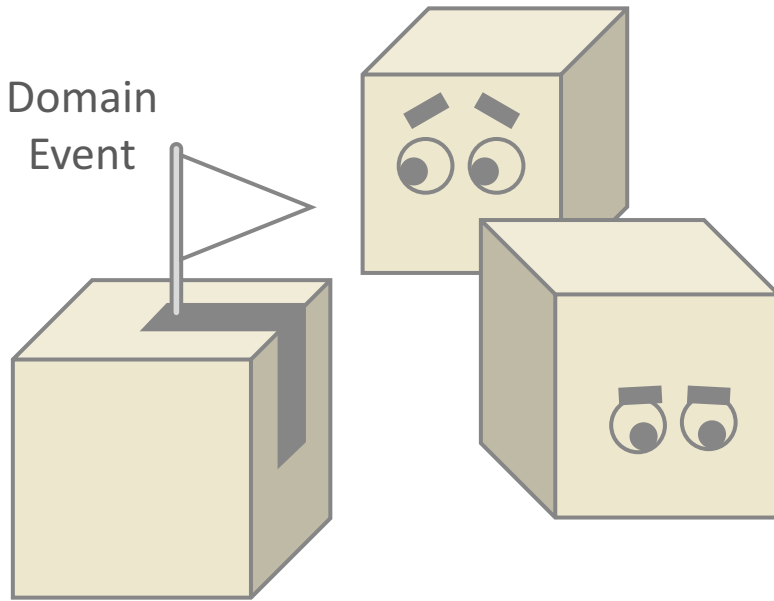

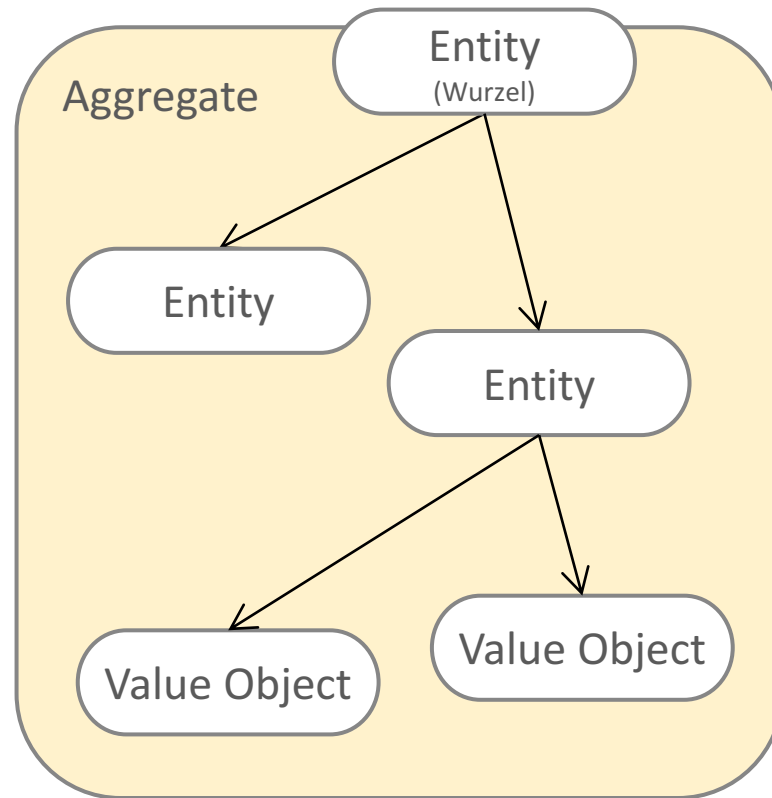

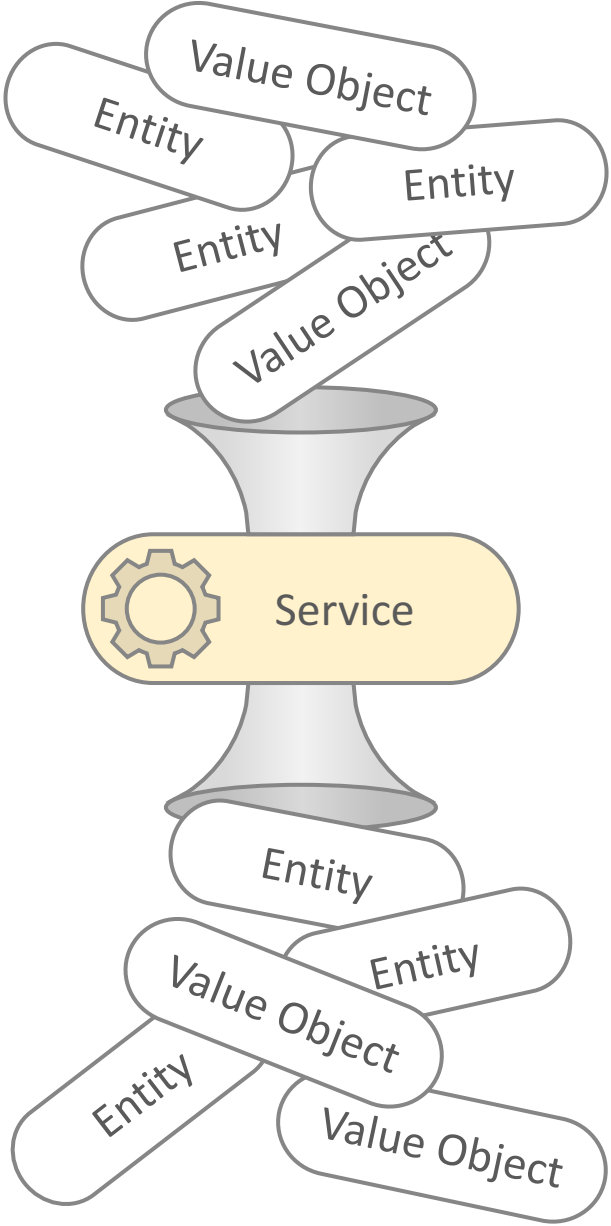

WAM

@hschwentner



Copyrighted material

THOMAS BRUNNEN

Object-Oriented Construction Handbook

DEVELOPING APPLICATION-ORIENTED SOFTWARE WITH THE TOOLS AND MATERIALS APPROACH



MCC [a] punkt.vorlag

Horst Zülliglowen

Das objektorientierte Konstruktions- handbuch

nach dem
Werkzeug- & Material-Arzt



punkt verlag

Dirk Baurer

Wolfgang Baurer

Udo Beck

Udo Bode

Wolfgang Brand

Wolfgang Bruns

Wolfgang Buch

Wolfgang Buch

Wolfgang Buch

Wolfgang Buch

Wolfgang Buch

Wolfgang Buch

Wolfgang Buch

Wolfgang Buch

Wolfgang Buch

Wolfgang Buch

Wolfgang Buch

Wolfgang Buch

Wolfgang Buch

Wolfgang Buch

Wolfgang Buch

Wolfgang Buch

Wolfgang Buch

Entwurfsmetaphern



Foto: Dallas Museum of Art/Wikipedia



Material



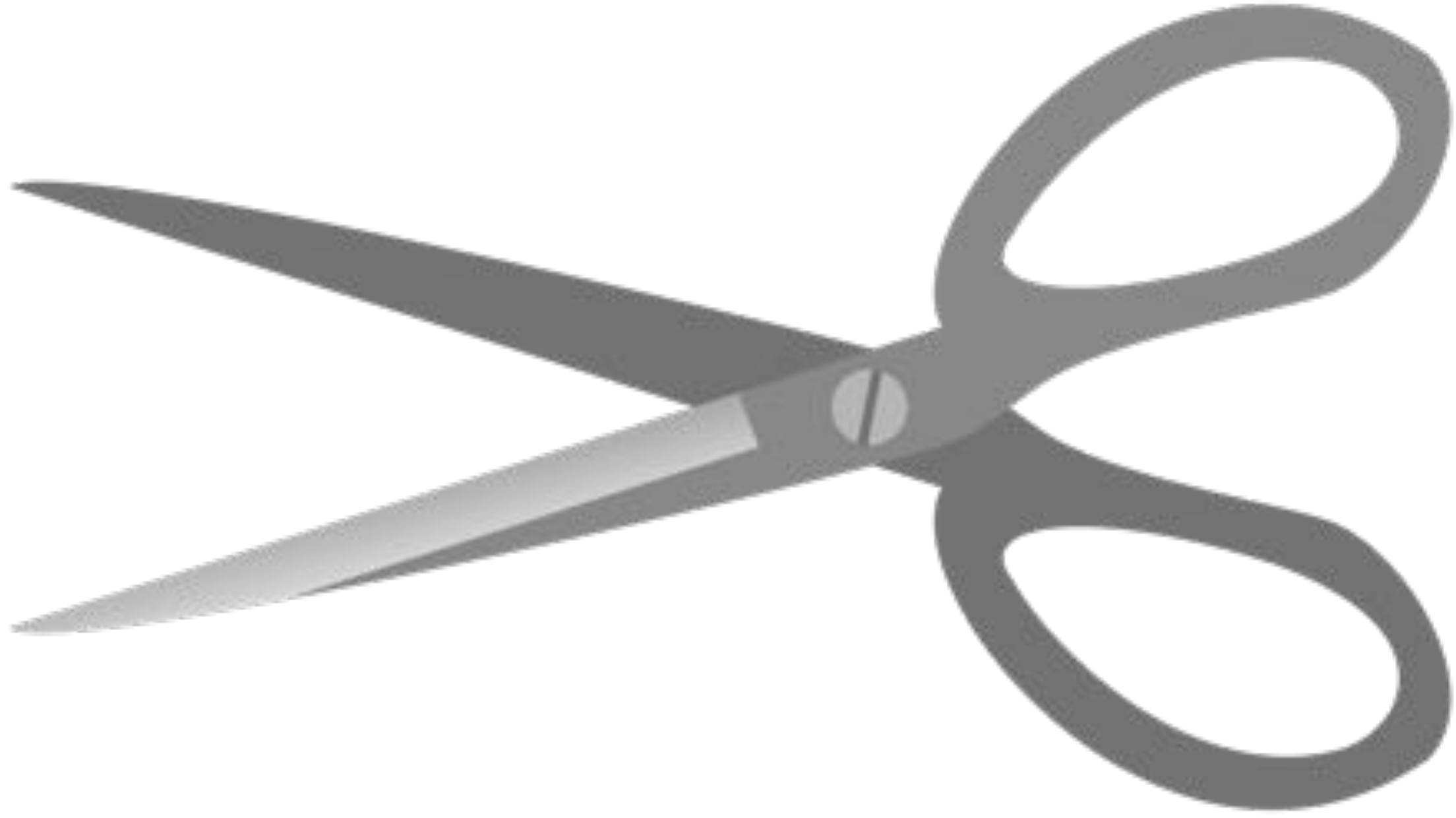

Werkzeug



Foto: Wolfgagn Lonien/Wikipedia

Automat

Material === passiv





== *aktiv*

@hschwentner



N

76°

388.1 m





Strategic Design

@hschwentner



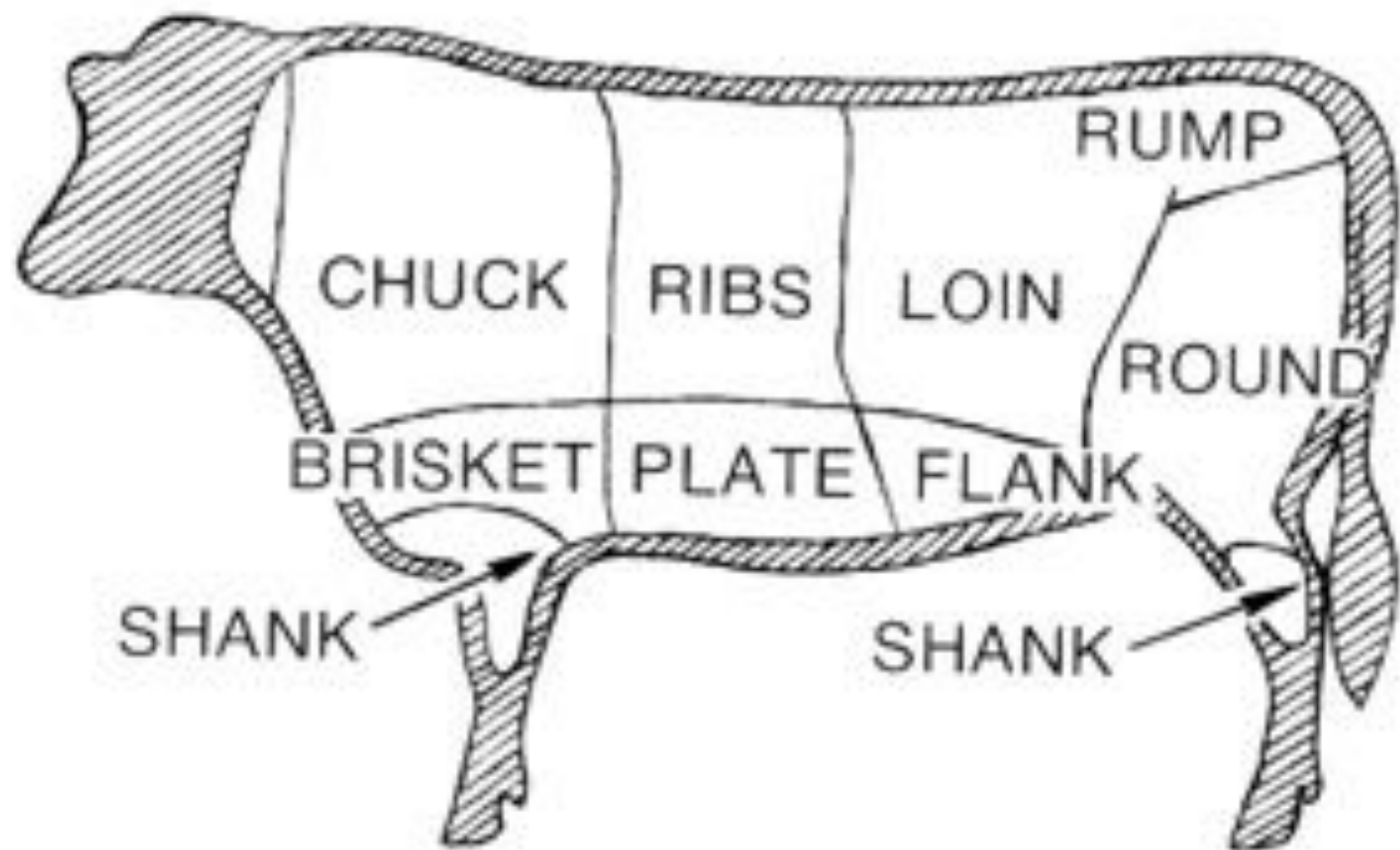









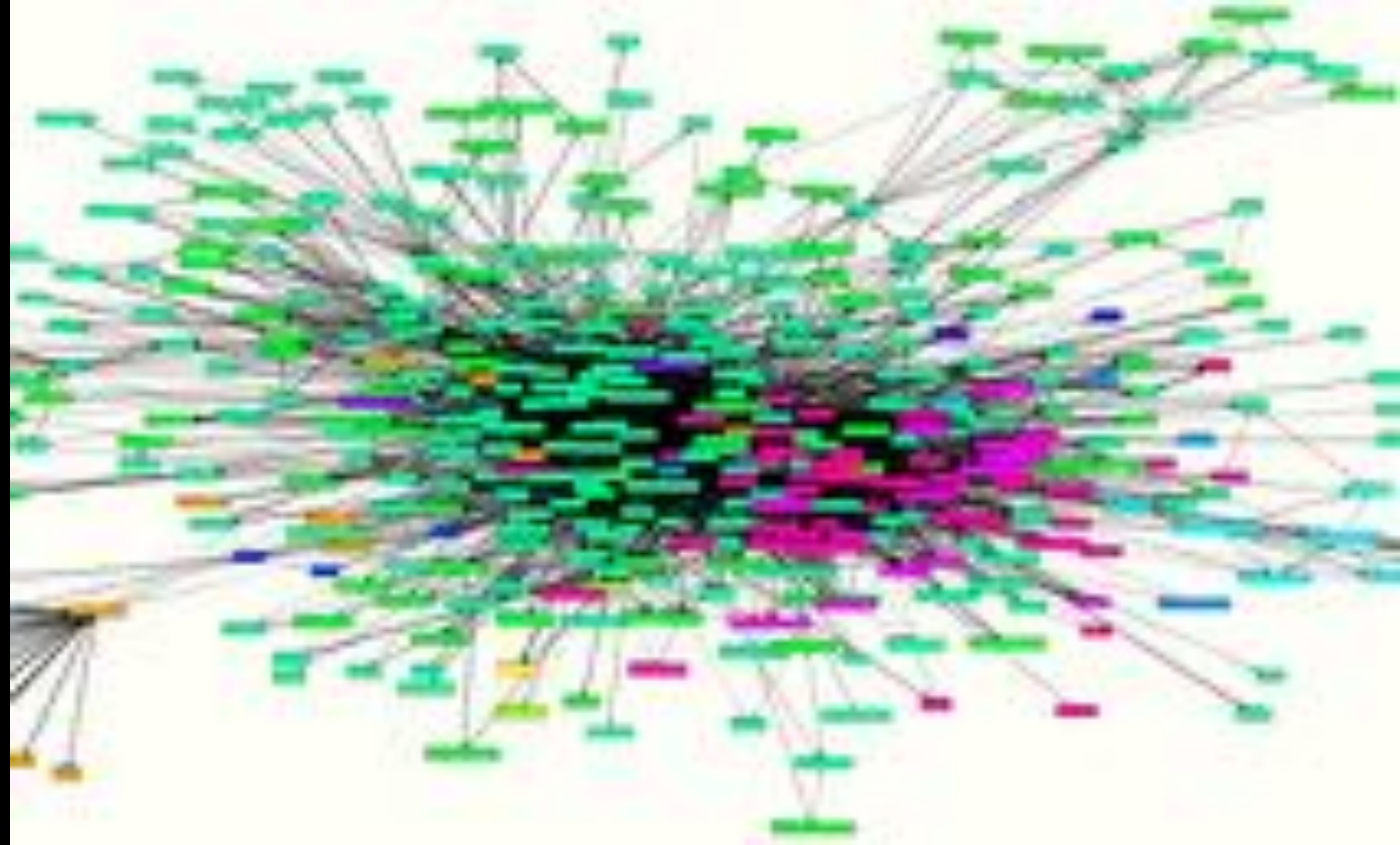

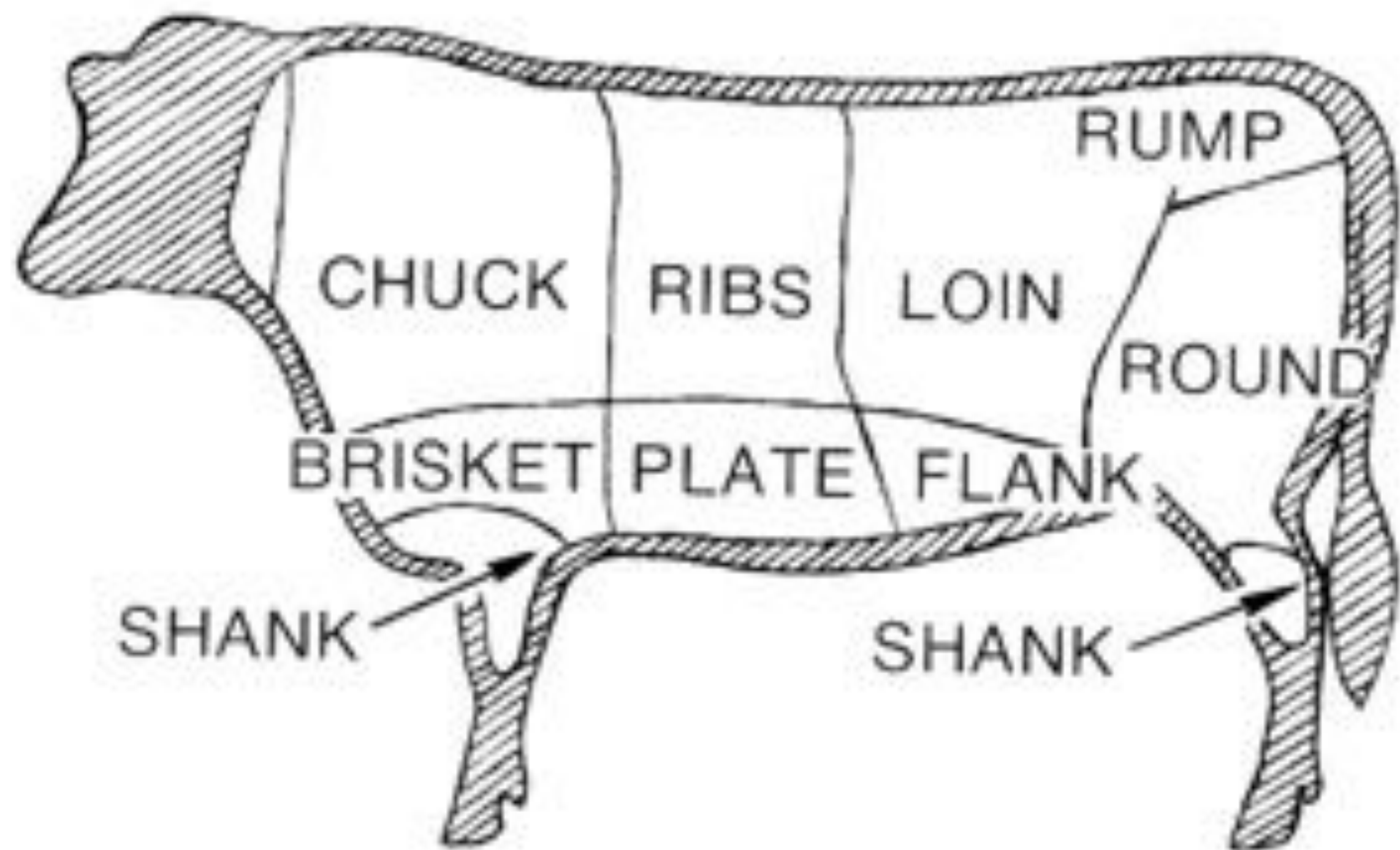









“Organizations which design systems are constrained to produce designs which are copies of the communication structures of these organizations.”

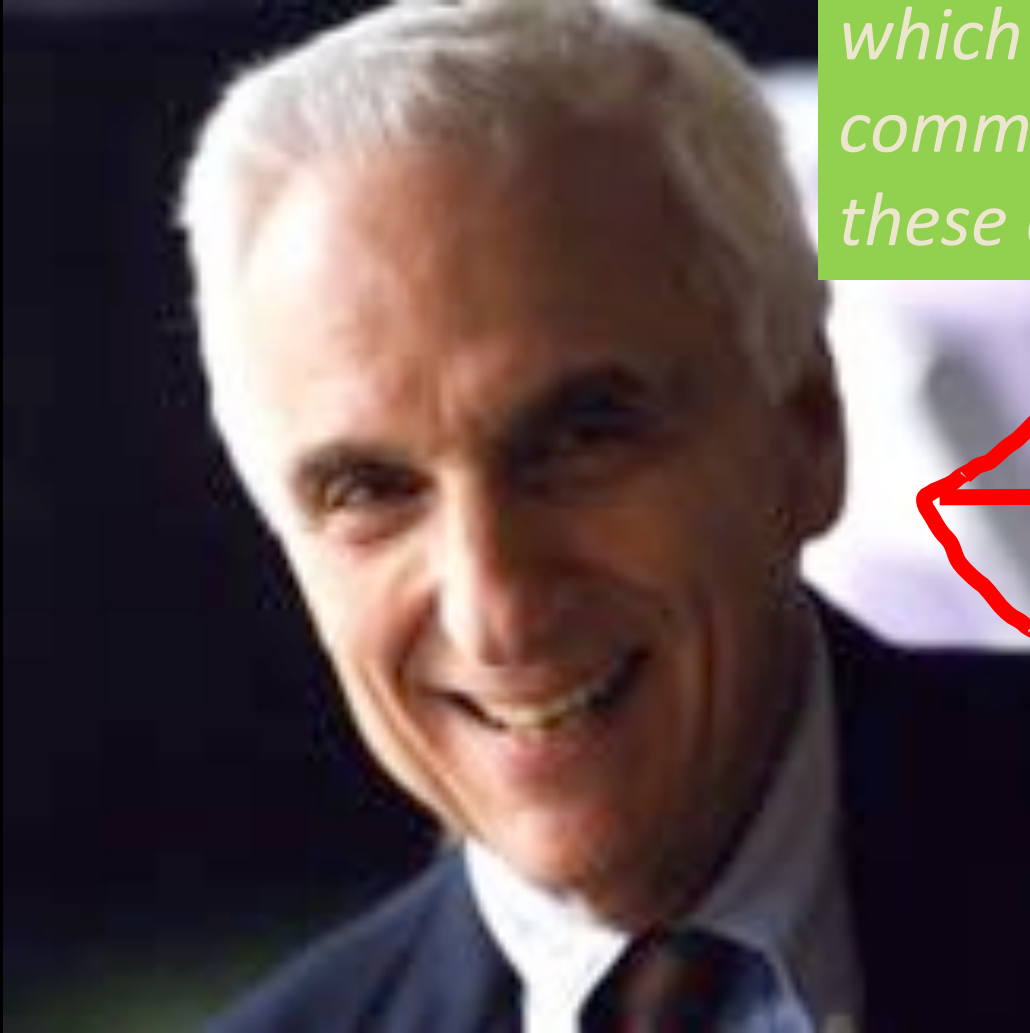

Melvin Conway

“Organizations which design systems are constrained to produce designs which are copies of the communication structures of these organizations.”



*Melvin Conway
(1967)*

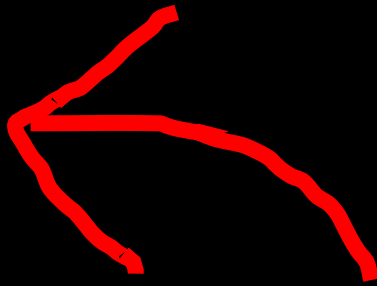

“The organization of the software and the organization of the software team will be congruent.”

Eric Raymond



*“If you have four groups working on a compiler,
you'll get a 4-pass compiler.”*

Eric Raymond



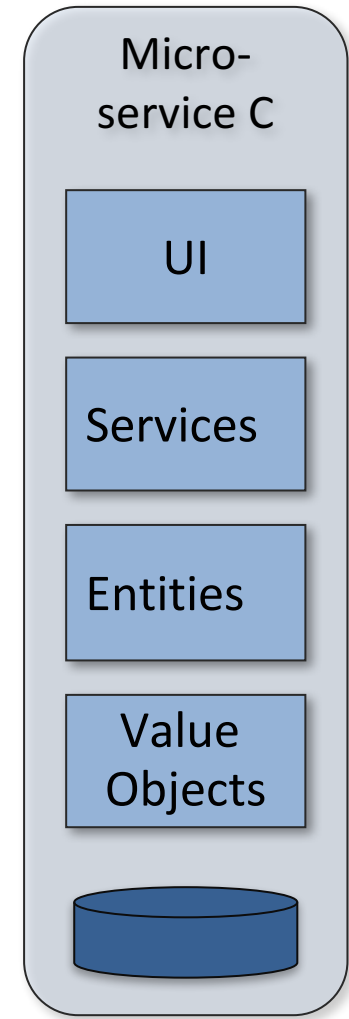
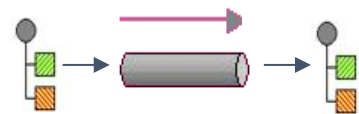
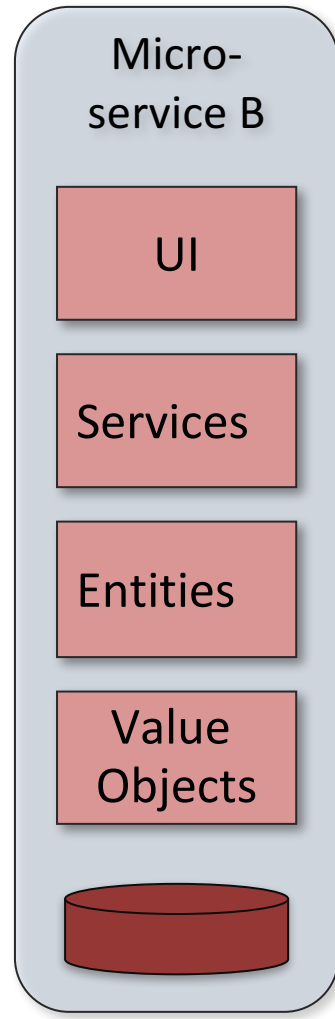
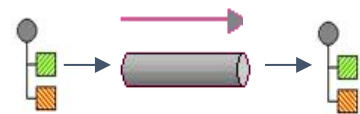
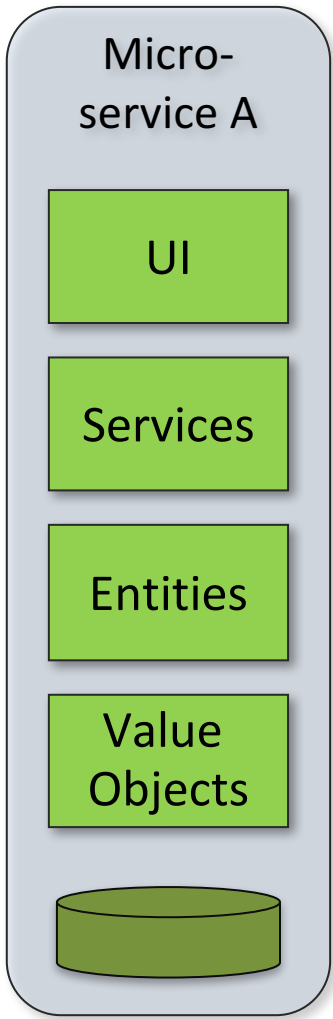

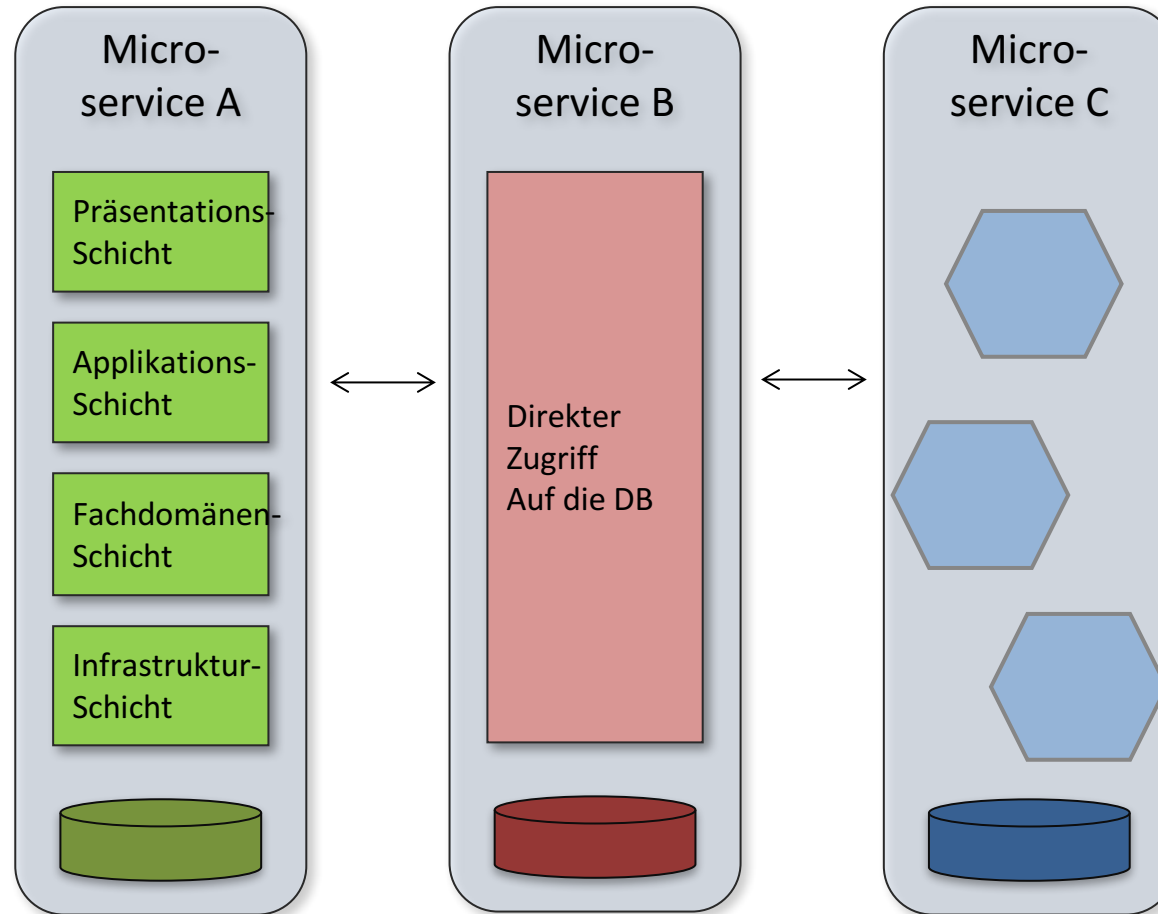





literatur

@hshwentner

speakerdeck.com/hschwentner

@hschwentner

Domain-Driven

DESIGN

Tackling Complexity in the Heart of Software



Eric Evans
Foreword by Martin Fowler



Foto: H. Schwentner



DOMAIN-DRIVEN
DESIGN
DISTILLED

VAUGHN VERNON

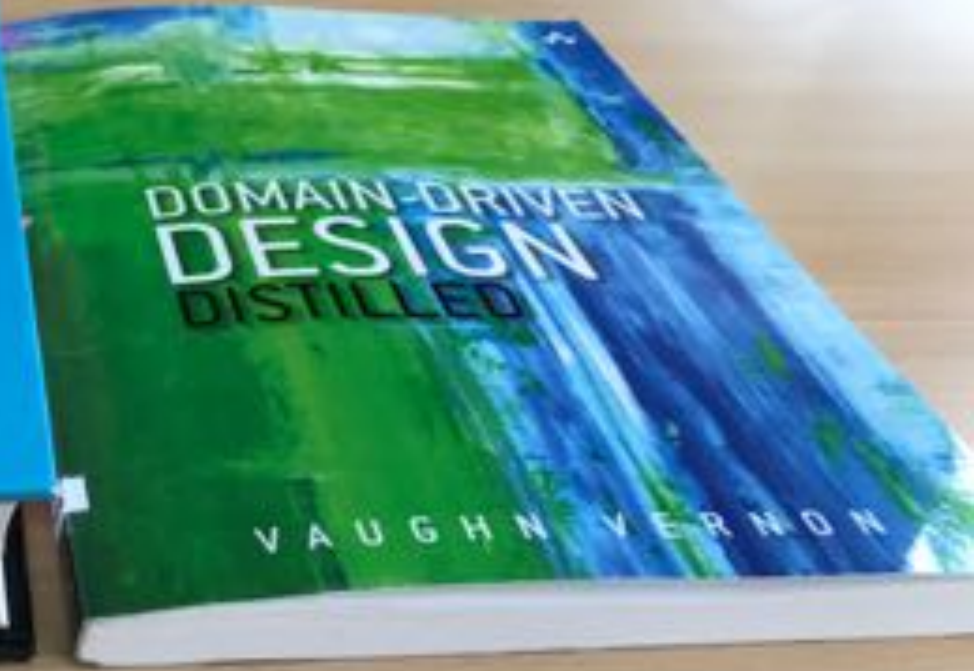
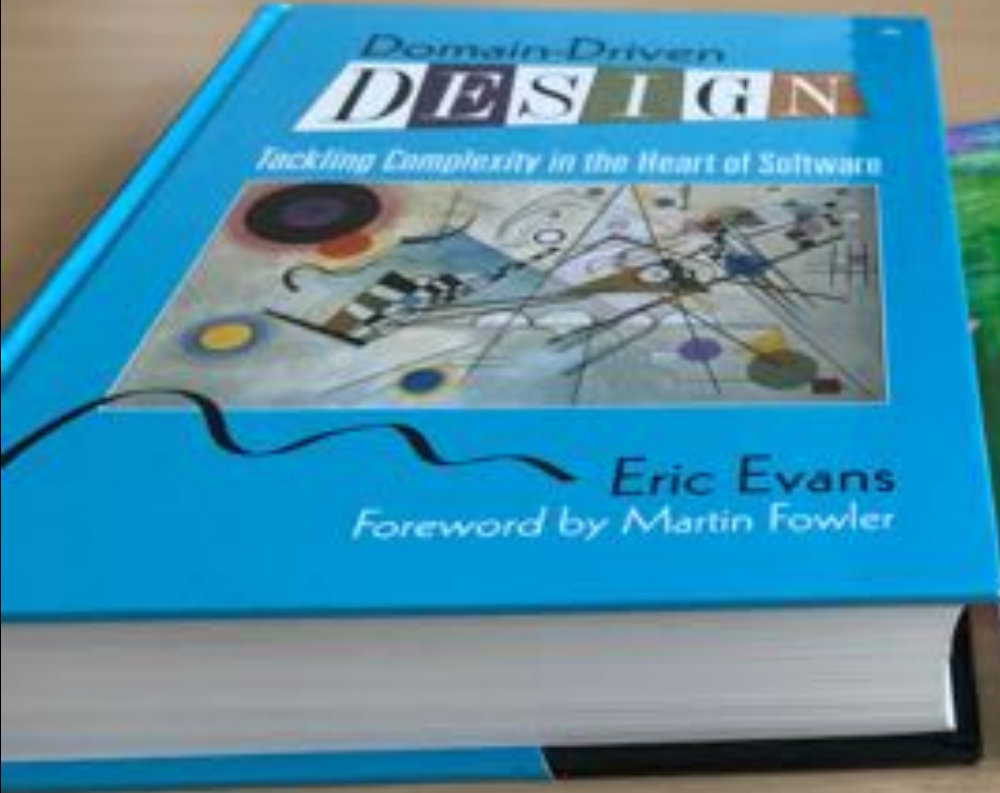
Foto: Amazon

Übersetzung gerade erschienen



Foto: Amazon



Vaughn Vernon

Domain-Driven Design kompakt

→ Aus dem Englischen übersetzt
von Carola Lilienthal und Henning Schwentner

dpunkt.verlag

THEMEN-DOSSIER



entwickler.kiosk

Domain-driven Design

Wie Software-Architekturen
von DDD profitieren

<https://entwickler.de/online/development/gratis-lesen-entwickler-kiosk-themen-dossier-domain-driven-design-579749361.html>



Copyrighted material

THOMAS BRUNNEN

Object-Oriented Construction Handbook

DEVELOPING APPLICATION-ORIENTED SOFTWARE WITH THE TOOLS AND MATERIALS APPROACH



MCC



punkt.vorlag

EVENT STORMING

Alberto Brandolini





Meetup

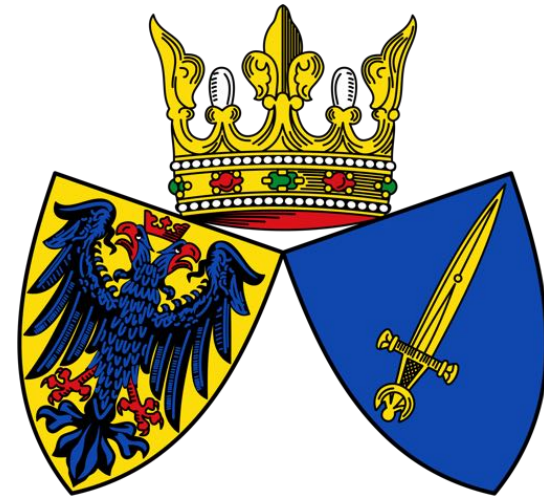
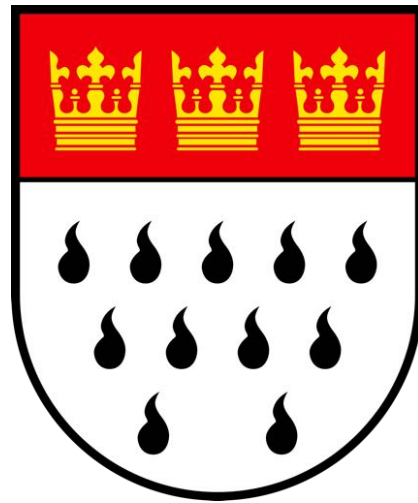
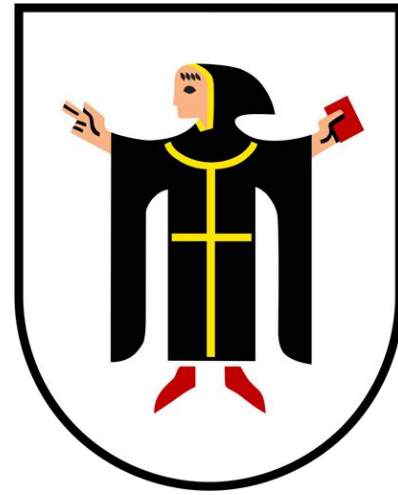
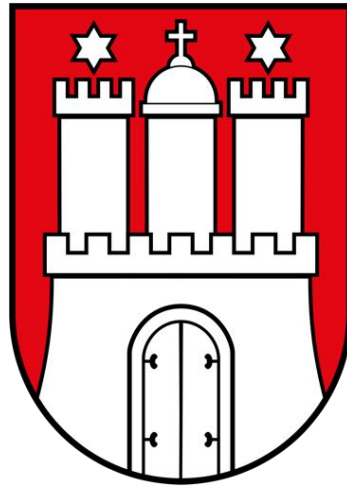





 @DDDger

 <https://dddgermany.herokuapp.com>



Germany's first DDD conference



Tutorium am Mittwoch

@hschwentner

Schwarzwald (1. Obergeschoss)

Refactoring Legacy Code with the Mikado Method

Doc Norton

ca. 7 Stunden

Rebland (1. Obergeschoss)

Domain-Driven Design hands on

Henning Schwentner

ca. 7 Stunden

Fidelitas (Erdgeschoss)

Continuous Delivery in Dockerland

Nicolas Byl

ca. 4 Stunden

Rheinauen (1. Obergeschoss)

Workshop

Domain-Driven Design *konkret*



Schulung

Domain-Driven Design

Advanced Level

In diesem Modul lernen Sie, wie eine Fachsprache entwickelt, die Domain-Driven Design-Muster integriert und die Verbindung zu anderen Anwendungen hergestellt wird, um eine an die Fachsprache orientierte Anwendung im Kontext zu entwickeln.

In diesem Modul lernen Sie, wie eine Fachsprache entwickelt, die Domain-Driven Design-Muster integriert und die Verbindung zu anderen Anwendungen hergestellt wird, um eine an die Fachsprache orientierte Anwendung im Kontext zu entwickeln.

In diesem Modul lernen Sie, wie eine Fachsprache entwickelt, die Domain-Driven Design-Muster integriert und die Verbindung zu anderen Anwendungen hergestellt wird, um eine an die Fachsprache orientierte Anwendung im Kontext zu entwickeln.



Dr. C. J. Jandl



Dr. Carola Jandl



Henning Schwentner



Jim Kott

CREDIT POINTS

20 Methodische Kompetenz

10 Kommunikative Kompetenz

Anmeldung unter www.wps.de/ddd

WPS WORKPLACE SOLUTIONS

ISAQB

Foto: Henning Schwentner

Rabatt!

@hschwentner

A vintage television set with a silver or light-colored metal casing. The screen is white and displays the word "WERBUNG" in large, bold, black, sans-serif capital letters. To the right of the screen is a control panel. At the top of the panel are two large rotary dials. The upper dial is labeled "Loud" and has numbers 10, 20, 30, 40, 50, 60, 70, 80, 90, and 100. The lower dial is labeled "VHF" and has numbers 1 through 12. Below these dials are three buttons labeled "HOME", "MUSIC", and "BLOG". At the bottom of the control panel is a grid of small, circular buttons, similar to a remote control keypad, and a small rectangular display or indicator at the very bottom.

WERBUNG



BLUTSPENDEDIENST
HAMBURG



**Blutspende- und
Blutgruppen-Ausweis**
(gilt nur in Verbindung mit Personalausweis)

230772-ZIT-M018-01-12

FEEDBACK

@hschwentner

@hschwentner

Wie zufrieden



Wie zufrieden



Wurden Ihre Erwartungen bezüglich des Vertrags erfüllt?

Das Niveau für den zukünftigen Abschluss des Vertrags





einfach & schnell
öffnen

Happy End

Recycling



aus
Recycling-
papier



aus
Recyclingpapier



8x

Henning Schwentner

 hs@wps.de

 [@hschwentner](https://www.instagram.com/hschwentner)

